

ENGINEERING STANDARDS

BERKELEY WATER AND SANITATION DISTRICT

ADAMS AND JEFFERSON COUNTY, COLORADO



4455 W 58TH AVENUE, UNIT A

ARVADA, CO 80002

303-477-1914

ADOPTED JULY 2019

Table of Contents:

Definitions.....Page 3
Purpose and General Requirements.....Page 4
Engineering Standards.....Page 4
 General Repair Requirements.....Page 5
Summary for Developing Sanitary Sewer FacilitiesPage 5
Responsibility of Contractor.....Page 6-8
 Safety Precautions.....Page 8
Materials List.....Page 8-9
Sewer Design Requirements.....Page 10-16
 District Master Plan Compliance.....Page 10
 Extension of Sanitary Sewer Mains.....Page 10
 Waterline Crossings.....Page 13
 Manholes.....Page 14
 Sanitary Sewers in Easements.....Page 15
 Markers.....Page 15
 Abandonment.....Page 15
Plan Review Requirements.....Page 16-18
Development Review – Submittal Requirements.....Page 18
Sanitary Sewer Main Installation.....Page 19
 Ground Water Barriers.....Page 20
Manhole Installation.....Page 21-24
 Strength, Size, and Connector Type.....Page 21
 Base Slabs.....Page 22
 Concrete.....Page 23
 Joints between Manhole Sections.....Page 23
 Interior Corrosion Protection System.....Page 24
 Damp Proofing.....Page 24
Sewer Testing.....Page 25-31
 Video Inspection.....Page 25
 Leakage and Infiltration after Construction.....Page 26
 Alignment & Grade/Damaged or Defective Pipe in Place.....Page 27
 Compaction at Manholes.....Page 27
 Compaction for Sewer Mains.....Page 28
 Low Pressure Air Test.....Page 29-30
 Vacuum Testing Manholes.....Page 31
Warranty and Acceptance.....Page 32-35
 Initial Acceptance Procedures.....Page 32
 Settlement.....Page 33
 Final Acceptance Procedures.....Page 33
 As-built Submittal Procedures.....Page 34

Appendix 1 – Grease Trap Design.....Page 37-46
Exhibits.....Page 47-71
 Certification Block for As-Built Drawings.....Page 47
 Approval Block.....Page 47
 Certification of Initial Acceptance.....Page 48
 Certification of Final Acceptance.....Page 49
 General Sanitary Sewer Notes/Detail.....Page 50-71

Engineering Standards / Sanitary Sewer System Specifications

Definitions:

"Contractor" shall mean any person, corporation, or other entity acting as an independent contractor that is hired by either the District or other persons or entities; is authorized by the District to perform work on District facilities, on facilities to be connected to the District's facilities, or on facilities to be dedicated to the District; is authorized by the District to furnish materials within the District for use in connection with the District's facilities; and from whom the District will accept completed facilities so long as such facilities are constructed in accordance with the District's Rules and Regulations and Engineering Standards. All Contractors, hired either by the District, Developer or other persons or entities shall be required to comply with all District requirements.

"Developer" shall mean any person, firm, partnership, or corporation who may own or be developing land or an individual lot or lots within the District and/or seeks wastewater service from the District. A Developer shall be held directly responsible by the District for ensuring that all work performed by it or its Contractor(s) is completed in accordance with all District requirements and may be required to perform any obligations of a Contractor set forth herein.

"District" shall mean Berkeley Water and Sanitation District.

"District's Engineer" shall mean any representative of the consulting engineering firm engaged by the District in connection with general engineering services or the specific project or other individual designated by the District to provide inspection of the sanitary sewer system construction.

"Master Plan" shall refer to the District's document(s) which represents planning level information that projects population, demands, flows, and facility requirements for the District with regard to the wastewater collection systems.

GENERAL NOTES:

Purpose and General Requirements

This publication is to provide information to all owners, engineers, contractors, builders, developers and other interested persons or firms, on the District requirements with respect to design and construction of sanitary sewer systems within the District. This publication contains technical specifications for the design and installation of sewer service lines and mains and related appurtenances, and should be used in conjunction with the District Rules and Regulations by any firm or individual planning to design or construct sewer systems within the District.

All Developers and other interested parties planning to design or construct water systems within the District should contact the City and County of Denver Acting by and Through its Board of Water Commissioners (“Denver Water”) and must comply with the Rules, specifications and requirements of Denver Water in connection with the water improvements.

Wherever reference is made to standard specifications, i.e. ASTM, AWWA, etc., the latest edition or revision thereof shall apply.

Engineering Standards:

All sanitary sewer line design and construction shall adhere to the latest version of:

City and County of Denver Department of Public Works:

1. Sanitary Design and Technical Criteria Manual;
2. Storm Drainage and Sanitary Sewer Construction Details and Technical Specifications;
and
3. Wastewater Standard Detail Drawings

Erosion control and all roadway trenching, patching, and paving shall adhere to the latest version of Adams County’s Development Standards and Regulations or, for property within Jefferson County, Jefferson County’s Development Standards and Regulations, and be conducted pursuant to permit from the County in which the property is located.

In addition to the City and County of Denver Department of Public Works Sanitary Sewer Design and Technical Criteria Manual for Sanitary Sewer Study Requirements, flow monitoring may be required to establish the proper sizing for outfall lines. The District’s Engineer will determine if flow monitoring is necessary and shall approve and/or dictate the flow monitoring location as well as the duration of flow monitoring. Flow monitoring and analysis of the District’s sewer main capacity shall be completed at the Developers’ expense.

General Repair Requirements

Repairs to sewer service lines on property that **do not tie in** the District's sewer mains are not inspected by District staff. Please contact your plumber. Repairs to private sewer service lines on property that **ties into** the District's sewer main must be called in to the District with a minimum 48 hour notice (unless it is an emergency). Repair to a sewer service line may only be performed by a Contractor which has a current license agreement with the District. Materials used shall be in compliance with the District's required material list and installed following these engineering standards. The District will charge an inspection fee based on the current fee schedule. Street cut permits must be secured through the County if needed.

Colorado 811 must also be called for utility locates on the property.

Summary for Developing Sanitary Sewer Facilities within the District

The step-by-step procedure that must be complied with for constructing sanitary sewer mains within the District is described below. The list is intended to summarize and underscore for the Developer, the Design Engineer and Contractor, the requirements of the District associated with the design submittal, plan approval, construction, inspection, and acceptance phases of a project. Depending on the nature of the project, only certain items may apply.

1. Developer/Owner contacts the District to discuss, at a minimum, the following:
 - a. General description of the project, including size, land-use mix and location.
 - b. Project requirements based on the development's proximity to existing and master-planned District facilities.
 - c. Developer responsibilities for cost, design, and construction of master-planned utilities within the District.
 - d. Extension and Easement Agreements
2. Developer/Owner obtains copies of the District's Rules and Regulations and Engineering Standards.
3. For all non-residential users, the Developer/Owner shall contact the District to determine whether additional requirements will be needed.
4. "Preliminary design submittals" are transmitted to the District for review and approval. Upon receiving comments for correction (if any), the Developer/Owner shall provide written response to each comment with subsequent re-submittals.
5. Upon approval of the final design submittal, electronic drawing files shall be submitted. Any aspect of the electronic drawing files found not to conform with the District's mapping standards will require that the files be resubmitted, delaying the scheduling of the pre-construction meeting.

6. Pre-construction meeting shall be scheduled and conducted with the District, either in person or by phone/online meeting.
7. Developer/Owner begins construction.
8. Inspection of gravity sanitary sewer mains by District personnel and/or the District Engineer.
9. Service inspections are to be physically observed by a District personnel for sanitary sewer services, grease interceptors, sand/oil interceptors, etc.
10. Compaction testing, manhole vacuum air testing, and sanitary sewer pressure and deflection testing witnessed by District personnel and/or the District Engineer.
11. Sanitary sewer mains shall be CCTV video inspected with an approved pipe report prior to both initial and final acceptance.
12. Developer/Owner submits Record Documents to the District, including final plat information, record construction plans, and record electronic drawing files associated with the completed project.
13. The District and Developer/Owner will confirm that all documents pertaining to the development have been received and/or recorded according to the District's internal checklist(s).
14. The 2 year warranty period begins once the District receives the warranty bond (25% of project cost) and Initial Acceptance has been approved by the District Engineer.
15. Developer/Owner pays District all outstanding fees and all tap fees.
16. Final inspection of facilities by the District Engineer and District personnel prior to expiration of the warranty period.
17. Warranty repairs and punch list items, as required by the District, shall be completed by the Developer/Owner.
18. Final Acceptance is approved by the District and District Engineer. The Developer/Owner conveys ownership of the sanitary sewer extension via Bill of Sale and the warranty period is terminated.

Responsibilities of the Contractor:

The Contractor shall verify the horizontal and vertical location of all tie-in points and provide the data to the District's Engineer prior to construction.

The Contractor will identify the horizontal and vertical location of all existing utilities prior to construction. The Contractor will report any discrepancies to the District's Engineer immediately and prior to construction.

The Contractor shall be responsible for notifying the District, District's Engineer, and the County, if applicable, at least forty-eight (48) hours prior to start of any construction and /or

testing. If work is suspended for any period of time after initial start-up, the Contractor must notify the District and District's Engineer forty-eight (48) hours prior to re-start.

All work on sewer system improvements to be dedicated to or connect to the District-owned sewer system may only be performed by a Contractor which has a current license agreement with the District.

A pre-construction meeting must be arranged by the Contractor and held prior to the start of any work. The District, District Engineer, Contractor, Developer and Adams County or Jefferson County, if applicable, must be represented at this meeting, which will be held in person at the District's office unless otherwise arranged with the District. The District's working hours are from 8:00 a.m. to 4:30 p.m. Monday through Friday (excluding Holidays). Any construction work that requires District personnel or a District representative to be on site on weekends, holidays, or before 8:00 a.m. or after 4:30 p.m. Monday through Friday will be considered overtime work.

At all points of connection of new sanitary sewer mains to existing mains, the Contractor will be responsible for excavating and verifying location of the existing lines, prior to installation of any new construction. If it is necessary to shut down any portions of the existing sanitary sewer system to make such connection, the Contractor will meet with the District to discuss.

In the event bypass pumping is selected by the District, the Contractor will provide a completed "*Proposed By-Pass Pumping Questionnaire*" along with the proposed technical specifications for sanitary sewer bypass pumping to the District. No construction will take place until these documents are reviewed and written approvals are received from the District.

The Contractor shall assume full responsibility and expense for the protection of all public and private property, roads, curb, gutter, sidewalk, pedestrian ramps, cross pans, curb cuts, driveway cuts, structures, water mains, sewers, utilities, utility appurtenances etc., both above and below ground, at or near the site or sites of the work, being performed under the contract, or which are in any manner affected by the prosecution of the work or the transportation of men and materials in connection there with.

It shall be understood that the location of existing utilities shown on the drawings, are based on the best available information but are not to be construed as exact. During the design phase of the project the existing utilities were identified from existing plans and visible surface appurtenances. However, it is understood that all existing utilities were not marked, and it will be the Contractor's sole responsibility to verify and protect all existing utilities during construction. If additional utilities are discovered during the construction that are not identified on the plans this will not constitute a Change Order and the Contractor shall include all costs for locating, crossing, and protecting all existing utilities for such work in the bid price.

The Contractor shall insure that all residents have access from a public street to their property each night. When access to a resident's property cannot be maintained during normal working hours (weekdays), the Contractor must personally notify the affected residents twenty-four (24) hours in advance of the closure. Emergency access shall not be blocked at any time for any reason.

The Contractor shall submit a Sanitary Sewer Line Schedule of Construction Phases to sequence construction, line abandonment, testing, and sanitary sewer service reconnections. This shall be submitted to the District and the District's Engineer for review and approval, prior to construction.

The Contractor shall make his own provisions to acquire all water necessary for backfill compaction. The District will not provide any water/water meters to the Contractor, both should be obtained from Denver Water directly.

All excavations at the end of the day shall be backfilled and compacted. The sub-grade shall be protected per the County standards. The sewer main installation shall be inspected by a District representative prior to backfill.

All piping material and appurtenances shall be stored off the ground and protected from dirt and the weather. No pipe shall be installed with dirt or debris in the line.

Safety Precautions

All excavations shall be performed, protected and supported as required for safety and in the manner set forth in the operation rules, orders and regulations prescribed by the OSHA Federal Register.

MATERIALS:

All Materials used for sewer lines within the District shall be in compliance with the District's required material list, except as otherwise approved in writing by District's Engineer.

All material deemed unacceptable by the District or its authorized representative shall be removed from the jobsite.

All installed materials shall be free from defects. Any defective or damaged materials, including pipes and fittings that do not allow sufficient and uniform clearance for jointing, shall be marked and removed from the site.

Any material that is furnished by the Contractor to be installed in the work that is found to be damaged, defective, or otherwise unsatisfactory, shall be removed from the site and repaired or replaced by the Contractor at no cost to the District.

Squeegee bedding to be used only. On-site material is not acceptable without approval of District's Engineer. No work shall be backfilled until the construction has been inspected and approved for backfilling by District's Engineer. If backfill does occur prior to inspection, the Contractor will be required to remove the backfill for inspection.

Pipe bedding shall be class "B" and shall conform to ASTM C-33 or D-448 gradation No. 6 or No. 67. Bedding depth shall be 6" under and around the sides of the pipe and 12" over the pipe. Consolidation in pipe zone shall be by hand tamping.

Fernco Strongback ®RC series pipe couplings will be required for pipe and lateral services.

All precast concrete shall be wet cast 5,000 psi minimum strength.

Duran Reliner® will be required for inside drop manholes. Stainless steel bolts will be required.

All manhole/vault exterior joints shall be wrapped in 12" wide conseal CS 212 or approved equivalent.

Manhole/vault barrel sections will require an exterior coating of bituminous waterproofing or approved equivalent.

All direct bury sanitary sewer mains shall be PVC, ASTM D-3034, SDR35 or approved equal.

All manholes shall be water tight wet precast concrete, a minimum of 48 inch in diameter with concentric cone, 24 inch cast iron ring (8" depth) and cover, unless otherwise specified, concrete adjustment rings shall be used for adjustment to match final pavement elevations and set in flexible butyl rubber caulking to obtain a water tight seal. Concrete adjustment rings shall be 4" minimum in depth to eliminate multiple joints.

All pipe to manhole connections shall be water tight flexible connections made with gasketed NPC Kor-N-Seal boots, manufactured by Trelleborg Pipe Seals Milford, Inc. With express permission of the District, cast-in-place A-Lok X-cel connections manufactured by A-Lox Products, Inc., can be used. For the connections to remain flexible, grouting shall be in compliance with manufacturer's recommendation.

Precast Manhole joints shall be water proof and constructed with a mastic strip equaling in three-quarter inch by one and one-half inch ($\frac{3}{4}$ " x $1\frac{1}{2}$ ") widths and continuously placed with no gaps or separations.

All manholes shall be plumb within one-eighth inch ($\frac{1}{8}$ ") per one foot (1').

Geotextile fabric and 2" minimum diameter crushed rock shall be used in a sub-bedding base depth of 18" minimum when ground water, unsuitable or unstable soils are present.

See additional information at Sanitary Sewer System Details Exhibits section.

SEWER DESIGN REQUIREMENTS

All sanitary sewer main installations shall conform to the District's Rules and Regulations and Engineering Standards. The District retains the right to adopt additional requirements and modify existing requirements as necessary for a particular project.

All sanitary sewer mains shall either be within public ROW or exclusive Berkeley Water and Sanitation District easements.

Sanitary sewer main lines are to be a minimum distance of five feet (5') from lip of gutter pan

For new developments, no parallel sewer mains to existing sewer mains will be allowed. The Developer will upsize the existing sewer main at his/her expense

The opening or channel in the manhole must be no less than the diameter of the pipe and no less than the manhole diameter minus 4 inches in length to accommodate equipment necessary to maintain the sewer line.

***Oil and Grease Interceptor design and installation specifications are shown in Appendix 1**

District Master Plan Compliance:

All proposed facilities shall comply with District criteria and be designed with sufficient capacities to meet, at a minimum; the service needs generated by the proposed development. Developers are advised that the District has prepared master plans within its service area for the sanitary sewer mains, which require facilities in certain locations to be upsized, improved, repaired, or replaced.

In the event that the Developer is directed by the District to construct a portion of a master-planned sanitary sewer main, costs required to construct mains in accordance with the District's master plans will be paid for by the Developer as an obligatory cost of developing land within the District. These requirements shall be discussed during the initial meeting. Payment assistance from the District via rebate agreements will not be made available to any Developer.

Extension of sanitary Sewer Mains:

When no existing District facilities exist adjacent to a proposed development, it shall be the Developer's responsibility to pay for the extension of existing sanitary sewer facilities to provide service to the site. Moreover, it shall be each Developer's responsibility to extend these facilities to the most distant point (or points) in each development, as determined by the District, so that adjacent developments are in turn able to continue extending the facilities in the future.

Any design requiring an extension of a sewer main or installation of a manhole will be inspected by the District's engineer and personnel as needed during installation. The developer will be responsible for the cost of the inspections.

Design Flow

Wastewater collection facilities shall be sized to meet the requirements of projected peak wastewater flows. Wastewater flows shall be calculated based on full development of the area or basin to be served by the proposed facilities. No roof drains, foundation drains, surface drainage, or any other source of surface, storm water runoff, or groundwater may be discharged to a sanitary sewer. Network modeling shall be conducted using a spreadsheet or similar approach such that an average daily flow for each pipe is developed. These average daily flows should then be used to determine the peaking factor and peak flow for each individual pipe in the system. The sewer main's hydraulic capacity shall be such that the sewer is flowing at no more than 50% of the full depth at the calculated future peak flow rate. The wastewater flow parameters in the table below shall be used to determine the minimum sewer capacity required:

Design Values	
Average Daily Flow (per unit)	
Single Family Detached Residential(gpd)	200
Multi-Family Residential (gpd)	140
Commercial/Industrial (gpd)	500
Hotel/Motel (gpdr)	140
Schools (gpssd)	15
Notes:	
<ol style="list-style-type: none"> 1. Commercial loading shown should not be applied for high water use applications (e.g. carwashes, Laundromats, medical facilities, etc.). Please contact the District for guidance on high water use commercial applications. 2. Industrial loading shown should not be applied for high water use applications (e.g. concrete batch plants, bottling plant, activities that required large volumes of process water, etc.). Please contact the District for guidance on high water use industrial applications 	
ADF = Average Daily Flow (gpd) gpd = gallons per day gpdr = gallons per day per room gpssd = gallons per student/staff per day Peaking Factor = $3.53 (ADF/1,000,000) - 0.168$ Peak Flow = ADF x Peaking Factor Maximum Peaking Factor = 5.0 Flow values include an allowance for infiltration and inflow. Flows from known industrial contributions shall be determined on a case by case basis.	

Design Velocity

Sanitary sewers shall be designed to provide a minimum velocity of 2 feet per second at design peak flow. The maximum velocity should not exceed 10 feet per second. If the maximum velocity in any section of sewer correctly sized for ultimate development will be less than 2 feet per second during the initial years of operation and a reduction in pipe size would result in a pipe too small for future requirements, the pipe size will be selected based on the future requirements.

Pipe Sizes

Sanitary sewers shall be designed to adequately serve the area tributary to it when that area is fully developed. The minimum allowable size for a sanitary sewer main shall be 8-inch in diameter. The minimum allowable size for an individual service connection shall be 4-inch in diameter.

All changes in pipe size must be made at a manhole. A Manning's roughness coefficient of 0.011 shall be used with PVC gravity sewer pipe material when determining the velocity of flow in the pipe. A Manning's roughness coefficient of 0.013 shall be used with all other sewer pipe materials.

Slope

Sanitary sewers shall be constructed with uniform slopes between manholes. Changes in slope and direction will occur only at manholes. Minimum and maximum slopes shall be as follows:

Pipe Size (in)	Minimum Slope (ft/ft)	Maximum Slope* (ft/ft)
4 (Service lines Only)	0.0208	-
6 (Service lines Only)	0.0104	-
8	0.0040	0.060
10	0.0025	0.045
12	0.0020	0.035
15	0.0020	0.026
18	0.0020	0.020
21	0.0020	0.017
24	0.0020	0.014
*Higher maximum slope values may be acceptable, as long as the maximum flow velocity in the pipe does not exceed 10 feet per second or special provisions are made to protect against pipe displacement.		

Depth

Sanitary sewer mains shall be deep enough to convey sewage by gravity flow and shall have a minimum cover of 4 feet. Sanitary sewers shall not be deeper than 20 feet, unless specifically approved by the District. Where sanitary sewers are deeper than 20 feet, SDR 26 PVC sanitary sewer pipe and 60-inch diameter manhole(s) shall be used.

Termination

All sanitary sewers shall begin and end at a manhole. Where a sewer may be extended in the future, the terminal manhole shall have a 4 foot long (minimum) plugged stub out installed in the direction of the future extension using either a push plug or cap. Stub outs shall be plugged with an approved device at the terminal manhole and at the end of a 4 foot extension. Sanitary sewers must extend to the farthest edge of the property or platted subdivision to be served, and must terminate in public right-of-way or permanent easements granted to the District.

Waterline Crossings

Parallel installation of interceptors and sewer mains with water pipelines must be accomplished in a fashion to preclude contamination of the water facilities. The separation distance must be measured edge-to-edge of the sewer main and the water pipeline. The interceptors and sewer mains must be located no less than 10-feet away from (i.e., between pipes, outside to outside) and 1.5-feet vertically from the water pipeline.

If the sewer main crosses under the water main but less than 1.5-feet of clear space will exist, the sewer main must be installed in a pipe casing extending no less than 9-feet each side of the water main centerline. The pipe casing must be of watertight material with no joints. The casing pipe material may be steel, ductile iron, fiberglass, fiberglass reinforced polymer mortar (FRPM), or polyvinylchloride (PVC) with suitable carrier pipe supports. Alternatively, reinforced concrete encasement of the carrier pipe extending no less than 10-feet each side of the water main centerline may be used.

If the interceptor or sewer main crosses over the water main, the interceptor or sewer main must be installed in a pipe casing extending no less than 9-feet each side of the water main centerline. The casing must be a single section of steel or ductile iron pipe. The design must include means to support the sewer main to prevent settlement and permit maintenance of the water main without undue damage to the sewer main.

If the minimum clearances cannot be satisfied, the Division will consider alternative designs on a case-by-case basis. The design must include documentation of methods that the sewer main and adjacent utility can be repaired without adverse impact on the other (e.g., planned, emergency).

Sewer installations near water supply wells must conform to requirements of the Colorado Design Criteria for Potable Water Systems and the Colorado Division of Water Resources, State

Board of Examiners of Water Well Construction and Pump Installation Contractors, Water Well Construction Rules.

At water and sanitary sewer crossings, the sanitary line shall not have a joint within six feet (6') of the outside dimension of the water pipe if within one and one-half vertical feet (1.5') of the water and/or above the water line.

Manholes

Manholes shall be provided at all changes in slope, pipe size, alignment, and at each junction of intersecting sewers. Maximum spacing between manholes shall not exceed 400 feet for sewer diameters of 15-inch and smaller. Maximum spacing of manholes shall not exceed 500 feet for sewers greater than 15-inch. For sewers 24-inches and smaller, manholes shall have an inside diameter of 4 feet. For mains larger than 24-inch, manholes shall have an inside diameter of 5 feet. All manholes shall be designed and constructed with a minimum drop through the manholes as follows:

- 0.1 foot for straight through sewers.
- 0.2 foot at a change in sewer alignment or intersection of connecting sewers.

When the downstream pipe leaving a manhole is a larger diameter than the upstream pipe entering the manhole, the crown elevation of both pipes shall match. All manholes shall be located in public street rights-of-way or within permanent easements granted to the District. All manholes shall be accessible by maintenance vehicles via all-weather drives. Where manholes are not located in paved streets, a gravel paved roadway surface shall be installed over the sanitary sewer for access to each manhole. Gravel surfacing shall be CDOT Class 6 road base material a minimum of 4 inches thick and 15 feet wide, compacted to 95% of the maximum density at optimum moisture as determined by AASHTO T99 (Standard Proctor) using a steel smooth drum roller. All manholes that are not located within paved streets shall have lockable lids. Manholes shall be located outside areas subject to flooding. When flood prone locations cannot be avoided, the District, at its sole discretion, may allow the installation of manholes designed to prevent the entry of surface runoff.

Changes required to correct design errors or to adjust for field conditions shall be approved by the District prior to the installation or adjustment to the affected portion of the project. Where changes are significant in the opinion of the District, resubmittal of the plans shall be required.

The Contractor shall safely maintain in good working order at the project site, one copy of all approved plans, specifications, addenda, written amendments, change orders, work change directives, field orders, and written interpretations and clarifications, clearly annotated to describe all changes made during construction. These documents shall be available for reference at the request of the District.

Upon completion of the work, any deviations from the approved design and any pertinent notes and comments regarding construction conflicts shall be transferred to the approved plans and electronic drawing files and subsequently submitted to the District and District Engineer as the

“Record Documents” for the project. The submittal shall consist of one full-size plan set with edits/changes clearly notated and the corresponding record electronic drawing files in both AutoCAD.

Sanitary Sewers in Easements

The District will review and approve the dedication of easements when the construction of District facilities within public rights-of-way is not feasible. When pipelines are constructed in easements, the minimum easement width shall be 20 feet. All sewer exclusive easements widths shall adhere to the City and County of Denver Department of Public Works Sanitary Sewer Design Technical Criteria Manual.

In the event that a nonexclusive easement is needed for both water and sanitary sewer facilities to be constructed, the District’s minimum required easement will be 30 feet or Denver Water’s current requirement, whichever is greater. Easements shall be accurately shown on the as-built plans and all pipelines and appurtenances shall be a minimum of 10 feet from the edge of the easement. Access must remain open to all facilities located in easements. Exclusive easements may be required for Master Planned pipelines. The District’s Engineer reserves the right to require additional easements and/or more than ten feet (10’) to the edge of the easement, depending on the depth of the sewer.

For any proposed easement, the Developer shall provide to the District for review an easement agreement (in the form provided by the District), exhibit, and legal description.

Markers

In areas where sewer mainlines are placed in easements, all manholes and force main valves shall be identified with four-inch (4”) steel marker post, offset as directed by the District’s Engineer and painted yellow, with the distance (in feet) to the manhole or valve and the appropriate identifying initials stenciled in black.

Abandonment

Requests to abandon an existing (public or private) sewer line must be submitted by the property owner(s), which are or could potentially be served by the facility to be abandoned, in writing to the District Manager for approval. The request will provide a detailed site plan along with justification for abandonment. Proof of property ownership must also be submitted.

The District Manager will review each request and determine if it can be granted. If permission to abandon can be given, the District Manager will issue a Sewer Abandonment Permit. The owner or his agent is then responsible to schedule an on-site inspection at least 24 hours in advance of the desired inspection time. All sewer work will be performed to meet these engineering standards.

For sanitary sewer mains to be abandoned, the Contractor shall place mechanical plug in the pipe and fill 5’ of abandoned sewer lines with controlled low slump materials (CLSM).

For sanitary sewer manholes to be abandoned, the Contractor shall: a) remove cast iron cover, rim, concrete adjustment rings, and cone, b) Fill the lower 1/3 of manhole with CLSM and remainder of manhole with clean backfill, and c) Salvage manhole cover and metal grade rings and coordinate delivery with District personnel.

Service Lines

Sanitary sewer service lines must be located on property owned by or in an easement owned by the property owner receiving service. All sewer services shall have a cleanout installed on the service line in order to facilitate proper maintenance by the owner. Proper clearance shall be provided for access to cleanouts. All sanitary sewer service lines that are one hundred feet (100') or longer will be required to install two-way clean-outs. Service lines shall be a minimum size of 4 inches installed at a minimum slope of 1/4 inch per foot. Where multiple 4 inch service lines connect to a single service, a minimum 6 inch service line must be constructed. Six-inch (6") service lines shall require connection to the main with a manhole.

Sanitary sewer service connections shall be sewer wyes. Sewer service wyes for each unit shall be staked by a survey crew and furnished and installed by the contractor. The Contractor shall furnish to the District and the District Engineer as constructed vertical and horizontal location of wyes.

Plan Review Requirements:

The purpose of this approval procedure check list is to familiarize all interested parties in the procedures followed by the District concerning District plan approvals.

General Utility Plans Check List

Cover Sheet

The following must be included on the Cover Sheet:

1. Name of Project
2. Vicinity and location Maps
3. P.E. Stamp and Signature
4. Sheet Index
5. Fire Department Signature Block (Water Lines)
6. Notification Block
7. Reviewed by Signature Block
8. District's Signature Block

Plan and Profile Sheet

1. Where possible, plan should be located in line above profile.
2. Plan should indicate manhole numbers, distances between manholes, size of pipe, grade, flow directions, and interior angles of sewer lines at manholes.
3. Profile should include manhole numbers, depth of cut on manholes, length and size of pipe, invert flow direction, and invert elevation.
4. Grade shall be calculated by dividing the difference between the outlet of the upstream manhole and the inlet of the downstream manhole (as shown) by the distance between centers of the two manholes.
5. Street names, lot and block numbers and North Arrows.
6. Match lines with sheet numbers on both plan and profile.
7. Distances from street centerline or property line of manholes that are located on curved streets. Centerline dimensions are preferred. All manholes are to be located by dimensions in two directions.
8. Plan scale: horizontal 1" = 50' or a scale that best depicts the improvements.
9. Sheet sizes shall be 22" x 34"

Overall Utility (Sewer)

1. Required Notes (See attached sheets for examples of General Notes and Sanitary Sewer notes required by the District)
2. All Street Names
3. North Arrow and Scale (1"=100' Maximum)
4. Indicate individual sheet numbers for specific sections of lines to be shown on following sheets.
5. Lot and block number and from lot dimensions.
6. A list of quantities shown for both sewer and water.

Title Blocks

1. Title, Date, Sheet Number
2. Designed by, Drawn by, Checked by.

Sanitary Sewer Plans

Overall Sheet

1. All MH numbers, distances and sizes of lines, directional flow arrows.
2. Sewers are generally located five feet (5') south or west of street centerlines. On curved streets, manholes may be located on centerlines providing no portion of the sewer line crosses the street centerline. Design should attempt to minimize the number of manholes. The centerline of sanitary sewer shall be a minimum of five feet (5') from the lip of curb and gutter pan on the street sides.
3. Extra notes, such as tie-ins to the exiting lines, and verification of existing inverts and compaction locations prior to start of new construction, should be shown.
4. Manholes sequencing should be logical and non-confusing. All subdivision manhole numbers must begin with the abbreviation of the subdivision and be approved by the district.
5. "As-builts" must have all wye locations, stationed from downstream manhole, and must indicate type of pipe and materials used.
6. "As-builts" must also include a final fixture count for all buildings constructed in the project area.
7. Sheet numbers relating to specific plan and profile sheets should be shown.
8. Sewer Hydraulic data including Q, V, D, S, N, and peak flow factor at the point, or points where proposed sewer is tied into existing sewer. This should be based on Manning's Formula for flow in open conduits and flow generation per applicable jurisdictional agency.

DEVELOPMENT REVIEW- SUBMITTAL REQUIREMENTS

1. Any Developer seeking to construct sewer improvements to connect to the District's sewer system shall submit engineering plans to the District for review and approval prior to the commencement of construction, along with a plat showing all proposed and existing ROW, proposed District easements and a transmittal letter, giving pertinent information such as review desired and contact person.
2. All submittals shall conform to all the rules, regulations and engineering standards of the Berkeley Water and Sanitation District (BWSD), Denver Water "***Engineering Standards***" and "***Capital Projects Construction Standards***", the City and County of Denver, Department of Public Works, "***Sanitary Sewer Design Technical Criteria Manual***" and "***Storm Drainage and Sanitary Sewer Construction Detail and Technical Specifications***", latest editions.

3 The District's Engineer will perform an initial review of the submitted material for completeness. Incomplete submittals will be returned, un-reviewed, to the applicant. Submitted materials shall include any items discussed with the District or District Engineer such as sanitary sewer capacity studies, flow monitoring results and modeling, etc.

4 A completed response letter, in the BWSO format, will be provided with the 2nd and 3rd submittals.

5 Submit one (1) electronic copy, two (2) 22" x34" hard copies and one (1) 11" x17" hard copies of construction plans. Submit one (1) electronic copy of any studies or reports and two (2) hard copies of studies and reports. Applicant will comply with all comments.

SANITARY SEWER MAIN INSTALLATION

During the construction phase and prior to Initial Acceptance of all new sewer mains, a removable plug shall be installed in the downstream manhole just before the connection into the current sanitary sewer system, in an effort to prevent debris and ground water from entering the sewer system during installation of the new main.

The plug can be removed for video inspection of the line(s) only after all water and debris has been pumped/removed from the line and disposed of.

Installation of Pipelines in Open Trenches

Sewer mains shall be bedded in accordance with the District's Standard Details using imported bedding material consisting of 3/8" washed pea gravel or 1/2" #7 crushed granite. Sand is not considered a permissible bedding material.

All pipe and fittings shall be carefully examined for cracks and other defects immediately before installation. Proper implements, tools and facilities shall be provided and used by the Contractor for the safe and convenient performance of the work. All pipe, fittings, and appurtenances shall be carefully lowered into the trench piece by piece by means of an excavator, ropes or other suitable equipment in such manner as to prevent damage to the pipe and its protective coatings and linings. Under no circumstances shall materials be dropped or dumped into the trench.

Every precaution shall be taken to prevent foreign material from entering the pipe while it is being placed. If the pipe laying crew is unable to install the pipe in place without allowing debris to enter, the District may require that before lowering the pipe into the trench, a temporary plug or heavy, tightly woven canvas bag of suitable size shall be placed over each end and left there until the connection is made to the adjacent pipe. During laying operations, no debris, tools, clothing or other materials shall be placed in the pipe.

As each length of pipe is placed in the trench, the spigot end shall be centered in the bell and brought to correct line and grade. The pipe shall be secured in place with approved bedding materials.

At times when pipe laying is not in progress, all open pipe ends shall be closed by a watertight plug or other means. If water is in the trench, the plug shall remain in place until the trench is pumped completely dry. No pipe shall be laid when trench conditions are unsuitable.

The cutting of pipe for inserting valves, fittings or closure pieces shall be done in a manner without damage to the pipe so as to leave a smooth end perpendicular to the axis of the pipe. Flame cutting of pipe by means of an oxyacetylene torch is not allowed. Field-cut pipe lengths shall be filed or ground to resemble the spigot end of the manufactured pipe. When ductile iron pipe is to be cut in the field, the pipe to be cut shall be ordered as "GAUGED FULL LENGTH," and shall be specially marked to avoid confusion. After cutting, the cut end of the pipe shall be field gauged to determine if it is within acceptable tolerances prior to assembling the joint. All assembly instructions provided by the pipe manufacturer shall be complied with.

The laying of sewer pipe shall be commenced at the lowest point with the spigot ends pointing in the direction of the flow. All pipe and fittings shall be laid with ends abutting. They shall be carefully centered so that when laid, they will form a line with a uniform invert. Blocking under the pipe shall not be used except in connection with concrete cradles or encasements. The Contractor shall provide grade stakes by which the grade of the pipe shall be established.

The inside of the bell, the outside of the spigot end, and the gasket shall be thoroughly cleaned to remove oil, grit, excess coating, and other foreign matter, taking care not to leave any residue or introduce any dirt or bacteria into the pipe. The circular gasket shall be flexed inward and inserted in the gasket recess of the bell socket.

A thin film of gasket lubricant shall be applied to either the inside surface of the gasket or the spigot end of the pipe or both. Gasket lubricant shall be as supplied by the pipe manufacturer and shall meet current potable water industry standards. The spigot end of the pipe shall be entered into the socket with care to keep the spigot end from contacting the ground. The joint shall be kept straight while the spigot end is pushed into the bell. Contractor shall follow manufacturer's recommendation and standard means and methods during the installation of sanitary sewer pipelines. Pipe not furnished with a depth mark shall be rejected by the District.

Per manufacturer recommendation, pipe shall be installed such that the depth mark lines up with the bell face and does not proceed further. In cases where the pipe is inserted past the depth mark, the pipe shall be removed and replaced.

Aluminum foil/metallic detection warning tape shall be used for all new direct bury sanitary sewer mains. The tape will be installed 6" above the sanitary sewer pipe. Tape must be green in color.

GROUND WATER

Groundwater is to be anticipated during excavation anywhere in the District.

All excavations shall be kept free from excess groundwater accumulation during construction of sewer and pipeline and appurtenances.

Excessive groundwater shall be removed from excavations to provide a firm sub grade for installation of pipe and appurtenances; to allow pipe joints to be made in dry conditions; and to prevent entry of groundwater into the sewer pipeline under construction.

Trench and structure excavation shall be kept free from water accumulation until the installation of pipeline and appurtenances is complete to the extent that no damage from hydrostatic pressure or unsafe condition will result.

Groundwater discharged from excavations shall be made to an approved location in compliance with water quality control requirements of the receiving entity.

No groundwater may be discharged to any sanitary sewer system or facility under any circumstances.

Dewatering any excavation will require, at a minimum, a filter sock at the discharge, and pump intake protection. The contractor will obtain a State Dewatering Permit, if required.

Cut-off walls or flash fill shall be installed around the pipe or flash fill shall be installed around the pipe every 300' +/- and 10' from each side of the manhole. Flash fill must meet Adams County standards.

If ground water, unsuitable, or unstable soils are encountered a sub-bedding base of no less than 18" using a minimum of 2" diameter crushed rock surrounded and covered by Geotextile fabric shall be installed

MANHOLES:

Sewer manholes shall be constructed complete with covers, steps, fittings, and other appurtenances in accordance with the District's Standard Details.

Strength, Size, and Connector Type

Manholes shall be constructed of precast concrete base, riser, and cone sections. Precast manhole bases, risers, and cones shall be manufactured in conformity with ASTM C478 and shall be designed for H-20 traffic loading. Lifting notches in manhole walls shall be filled with non-shrinking grout. Unless otherwise allowed by the District, precast manholes shall be furnished with resilient connectors (rubber boot sleeves) in the appropriate locations per the plans to accommodate all sewer mains connecting into the manhole. Manholes having an internal

diameter of 4 feet shall be used on sewer mains of 24-inch diameter or less. Manholes having an internal diameter of 5 feet shall be used on mains with diameters larger than 24-inch.

Cement type shall comply with ASTM C150, Type II containing not more than 5 percent tricalcium aluminate, or Type V. Water-cementitious materials ratio shall not exceed 0.40. Alternative materials proposed by the Contractor that will provide equivalent corrosion protection and durability may be submitted subject to review and acceptance by the District.

Manhole riser and precast base sections shall be circular with uniform outside diameters, and a minimum wall thickness of 1/12 of the inside diameter measured in inches, plus 1 inch.

Cones and Adjustment Collars

Manhole cones shall be of the eccentric type. The manhole barrel diameter below the cone section shall be maintained to a point not more than 48 inches from final grade, and shall then be tapered to an internal diameter of 24 inches such that the top of the cone sits 8 to 16 inches below final grade. Pre-cast concrete adjustment collars, mortared in place, shall be used on top of the precast cone to support the manhole frame at final grade. No more than 8 inches in adjustment collars may be used to bring the manhole ring to final grade. Additional barrel sections shall be added for any height greater than 8 inches pursuant to District Details for conformance. All joints between concrete adjustment collars shall be sealed with two rows of a flexible mastic gasket material conforming to ASTM C990. There shall be a full bitumastic joint between all adjoining concrete riser and cone sections with two rows of flexible bitumastic material. No more than one cast iron traffic adjustment ring (riser) may be used to adjust the top elevation of the manhole. If more than one cast iron adjustment ring is required to bring the ring to final grade elevation, the Contractor shall use additional concrete adjustment collars instead. Cone wall thickness shall be as specified for riser sections.

Base Slabs

Manhole bases for manholes constructed along new sewer mains shall be precast with the base and first riser section cast monolithically. Precast manhole bases shall be set on a minimum 6-inch thick bed of 3/4-inch to 1-1/2 inch crushed rock placed on undisturbed earth.

Manhole bases for manholes constructed over existing sewer mains shall be cast-in-place concrete constructed on a minimum 6-inch thick bed of 3/4-inch to 1-1/2 inch crushed rock placed on undisturbed earth. Cast-in-place manhole bases may be used on new sewer mains only where connecting to existing sewer mains or if specifically approved by the District. Cast-in-place bases shall cure for a minimum of 3 days and achieve 80% design strength prior to installation of manhole barrel sections on the base and backfilling of the manhole. A corrosion protection system shall also be applied to the cast-in-place base following a 28 day cure time in accordance with the manufacturer's instructions.

Invert channels shall be cast monolithically with the manhole base unless otherwise approved. Invert channels shall have a minimum slope equal to mildest slope of any pipe coming into or

going out of that manhole. Side branches shall be connected with as large a radius of curve as is practicable. All inverts shall have a smooth clean surface.

The first riser sections for use with cast-in-place bases shall be provided with horseshoe-shaped boxouts for connecting piping to be grouted in, or with circular openings with continuous, circular, resilient connectors cast into the riser wall. Boxouts for grouting, if used, shall have surfaces grooved or roughened to improve grout bond.

Precast base sections shall be provided with circular openings, with continuous, circular, resilient connectors cast into the wall.

Resilient connectors (boots) shall be installed in accordance with the manufacturer's recommendations, except that connectors shall be positioned so that the sealing or resealing operations may be accomplished from inside the manhole.

Precast sections may be provided with lifting notches on the inside faces of walls to facilitate handling. Lifting notches shall not be more than 3 inches deep; holes extending through the wall will not be acceptable.

Steps

Manhole steps shall be located inside the manhole sections in accordance with ASTM C478. The steps shall be made of a copolymer polypropylene conforming to ASTM 2146 Type II, Grade 16906. The plastic shall encapsulate a 3/8-inch Grade 60 Steel Rebar. If additional steps need to be added to a manhole section, the steps must be epoxied into the holes that are drilled for the steps.

Rings and Covers

Manhole rings and covers shall be constructed in conformance with ASTM A48, free from cracks, holes, or swells. The minimum cover diameter shall be 24 inches with a traffic loading of H-20. All manholes that are not located within paved streets shall have lockable manhole rings and covers in accordance with the Approved Construction Materials List. All manhole covers used for sanitary sewers shall be furnished with the word "SEWER" cast on the cover.

Concrete

Concrete used in invert channels shall have a 28-day compressive strength of 3500 psi and shall contain not less than 6 sacks of Portland cement per cubic yard. All cement used in concrete and mortar shall conform to ASTM C150 Type II, or Type IIA. Aggregates shall conform to ASTM C33 and air-entraining admixtures shall conform to ASTM C260.

Manhole bases poured in place shall have a 28-day compressive strength of 3500 psi and shall contain not less than 6 sacks of Portland cement per cubic yard. Cement type shall comply with ASTM C150, Type II containing not more than 5 percent tricalcium aluminate, or Type V. Water-cementitious materials ratio shall not exceed 0.40. Alternative materials proposed by the Contractor that will provide equivalent corrosion protection and durability may be submitted subject to review and acceptance by the District.

Joints between Manhole Sections

All joints between manhole sections shall be sealed with two rows of a flexible mastic gasket material conforming to ASTM C990.

All manhole barrel sections shall be joined by a minimum of 8 inches wide of flexible mastic gasket material (i.e. Conwrap) to minimize or eliminate inflow and infiltration into to the sanitary sewer system.

Connecting Piping

When resilient connectors (boots) are used, the connecting pipe shall be carefully adjusted to proper line and grade, and the bedding material shall be compacted under the haunches and to the springline of the pipe from the manhole wall for the full trench width. The pipe shall be installed in the resilient connector prior to backfilling outside the manhole and shall be resealed as required after completion of the manhole and backfill. All visible leakage shall be eliminated.

The connecting pipe for installation with resilient connectors shall be plain end, square cut spigots and shall not protrude more than one inch inside the manhole wall. After completion of the manhole, the box-out shall be filled with mastic filler material, completely filling the space beneath the pipe and extending to at least the springline. The filler material shall provide a smooth, uniform surface between the inside diameter of the pipe and the manhole invert.

When approved by the District, direct penetration of sewer mains into a manhole wall without the use of resilient connectors shall be as shown in the District's Standard Detail for Drop Manholes or in the District's Standard Detail for Sewer Main Connections to Existing Manholes. For connecting main sizes whereby the hole can be cored smooth through the manhole wall, a waterstop gasket shall be installed around the pipe, aligned with the center of the wall, and the annular space between the cored opening and the pipe completely filled with non-shrinking grout. Alternatively, a modular seal (Link Seal or approved equal) may be used in place of the waterstop gasket and grouting method on cored openings, as long as a water tight seal can be ensured at the connection. Grouting of the annular space between the pipe and the manhole wall shall still be performed. When larger mains prohibit coring through the manhole wall, the hole shall be made as smoothly and uniformly as possible using methods approved by the District, and shall be no larger than necessary to freely accommodate the size of the connecting main. In accordance with the District's Standard Detail for Sewer Main Connections to Existing Manholes, a waterstop gasket and reinforced concrete collar shall be utilized to secure the connection. Any voids within the manhole wall between the hole and the connecting main shall be completely filled with concrete.

Painting

Before painting, castings shall be thoroughly cleaned and properly supported. All loose rust shall be removed by wire brushing. Castings shall not be handled until the paint is dry and hard.

Stubs

Stubs for future connections shall be provided in manholes at the locations indicated on the drawings. Stubs shall extend not less than 5 feet beyond the edge of pavement or as directed by the District and shall be terminated with a bell and plug.

Interior Corrosion Protection System

A corrosion protection system shall be applied to the interior surfaces of the manhole. The corrosion protection system shall adequately protect the concrete from corrosion caused by exposure to hydrogen sulfide. Corrosion protection systems shall be Sikagard "62" or equal. The corrosion protection system shall be factory applied to all precast manhole sections unless otherwise approved by the District. If the system is damaged during installation, it shall be repaired in accordance with the manufacturer's requirements.

Damp Proofing

Before backfilling is started, the outside surfaces of each manhole shall be coated with one heavy coat of coal tar epoxy. Surfaces to receive coating shall be dry. Damp proofing may be applied to precast units in the shop. If the shop coating is damaged during construction, a touchup coat shall be applied and allowed to dry prior to backfilling.

SEWER TESTING:

Prior to final acceptance of the work, tests for the tightness of construction shall be coordinated and executed by the Contractor in accordance with these Standards. All testing shall be paid for by the Contractor and conducted under the observation of the District.

The Contractor shall be solely responsible for insuring that no obstructions or deflections exist within the completed sewers. Any obstruction found shall be removed and if necessary, the sewer pipe shall be replaced as directed by the District. Video inspection of all sewer mains is required by the District.

Video Inspection

All newly installed, repaired or rehabilitated sewer mains or trunk lines will be video inspected by a District approved video inspection crew at the Contractor's own cost prior to commencement of the two year warranty period and prior to the end of the warranty period. Any defects found during video inspection shall be repaired prior to connecting any services to the main. All new sewer mains must be jet cleaned prior to the video inspection. Contractor will dump water down the sewer main prior to video inspection. Contractor will then pump water out of downstream manhole and dispose of the water at a District-approved manhole. The maximum "belly" on low spots in the new sewer shall not exceed three-eighths inches (3/8").

Sanitary sewer video shall be completed uninterrupted in one direction from identified manhole to identified manhole. If the Contractor encounters a non-passable object, the camera shall be removed, and the pipe video completed from the opposite direction. Push camera footage is not acceptable. The camera shall be capable of rotating to capture video of each service and each manhole. The Videoing shall be in color. The Video shall be clear and document all manholes, direction of travel, sewer service distances and locations, any noticeable defects including roots, cracks, severe offset joints, depressions, signs of possible infiltration etc. Still pictures of any defects shall be clearly labeled.

All video inspections and reports must be submitted to the District and the District Engineer after the inspection is done.

Test for Leakage and Infiltration after Construction.

It is the intent of the sewer specifications that the completed sewer pipes of all types, along with the manholes and other appurtenances shall be watertight.

Each section of sewer between two successive manholes shall be tested for leakage and/or infiltration. These tests shall be performed subsequent to acceptance of compaction test results by the District's Engineer.

Even though a section may have previously passed the leakage or infiltration test, each section of sewer may be tested subsequent to the last backfill compacting operation in connection therewith, where, in the opinion of the District's Engineer, heavy compaction equipment or any of the operations of the Contractor or others may have damaged or affected the required watertight integrity and alignment, deflection or bends/sags of the pipe, structure and appurtenances. The Contractor shall furnish all materials required for the tests. Tests shall be made in the presence of the District's Engineer.

If the leakage and/or infiltration rate as shown by the tests specified herein is greater than the amount specified, the pipe joints shall be repaired or, if necessary, the pipe shall be removed and re-laid by the Contractor. The sewer will not be considered acceptable until the leakage and/or infiltration rate, alignment, deflections or bends/sags as determined by test, is less than the allowable.

The Contractor may at his option air test or water test for leakage except where (a) in the opinion of the District's Engineer excessive groundwater is encountered, then the infiltration test shall be made, or (b) where the difference in elevation between the invert of the upper structure and the invert of the lower structure is more than 10 feet, then the air test shall be made.

If, in the construction of a section of the sewer between structures, excessive groundwater is encountered, the test for leakage in conjunction with the other tests shall be used. The end of the sewer at the upper structure shall be closed sufficiently to prevent the entrance of water and pumping of groundwater shall be discontinued for at least three days after which the section shall be tested for infiltration. The infiltration shall not exceed 0.004 gallons per hour, per inch of diameter, per 100 feet of main-line sewer being tested and does not include the length of house laterals entering that section. Where any infiltration in excess of this amount is discovered before

completion and acceptance of the sewer, the sewer shall be immediately uncovered and the amount of infiltration reduced to a quantity within the specified amount of infiltration before the sewer is accepted, at the expense of the Contractor. Should, however, the infiltration be less than the specified amount, the Contractor shall stop any individual leaks that may be observed when ordered to do so by the District’s Engineer. The Contractor shall furnish all labor and materials for making the tests required.

All tests must be completed before street or trench is resurfaced, unless otherwise directed by the District’s Engineer.

Tests for Alignment & Grade/ Damaged or Defective Pipe in Place

Pipe Deflection Testing At least thirty (30) days after construction and flushing, all sanitary sewer mains constructed of PVC pipe shall be tested for vertical ring deflection using a deflectometer, properly sized “go, No-Go” Mandrel, or sewer ball. Maximum allowable vertical ring deflection is five percent (5%) of the pipe’s diameter. The following table outlines the acceptable Mandrel diameter for different sizes of PVC pipe (Table III).

Table III

Pipe Diameter (Inches)	5% Deflection Mandrel Dimensions Base Inside Diameter (Inches)	5% Deflection Mandrel
8	7.665	7.28
10	9.563	9.08
12	11.361	10.79
15	13.898	13.20
18	16.976	16.13
21	20.004	19.00
24	22.480	21.35
27	25.327	24.06

In areas where there are still some questions as to the condition of the sewer line, the District’s Engineer may require that pictures be taken of the interior of that part of the sewer line under question. After the pictures have been interpreted by the District’s Engineer, should the sewer line be interpreted to be defective, the cost of taking the pictures shall be borne by the Contractor. However, the District reserves the right to require pictures be taken of any curved line approved for installation. In all such cases, the pictures will be taken at the expense of the Contractor and will become the property of the District after interpretation.

Compaction at Manholes

The Contractor shall give special emphasis to the backfill around all manholes, appurtenances and structures. The backfill shall be placed in horizontal layers not exceeding 12-inches in depth and shall be adequately moistened and thoroughly tamped with air or vibrator plate or jumping jack compactor. At a minimum, 2 density tests will be taken at every foot at a manhole. All compaction will be initially observed by the District.

Compaction for Sewer Mains

Compaction tests will be taken by an approved testing laboratory at locations designated by the District Engineer. All expenses involved in these tests will be borne by the Developer/Contractor. Results of the tests will be made available to the District and the District Engineer immediately and copies of test results will be supplied to the District Engineer once per week. A final typed bound copy of final test results must be submitted to the District and the District Engineer at the end of the project. In all cases where the tests indicate compaction less than that required in these Standards, additional compaction and tests will be required until these specifications are met. Probationary acceptance of the lines by the District will be contingent upon satisfactory compaction results. Frequency of testing will be as follows:

- a. One (1) test at every above ground appurtenance (i.e. valve box, manhole) at two-foot (2') increments.
- b. One (1) test every two hundred (200) LF of mainline trench at two-foot (2') increments beginning two feet (2') above pipe to final grade and one test at final grade.
- c. Two (2) tests at every service line. One (1) test three feet (3') from main line and one (1) test two (2) feet beyond proposed edge of road all at two-foot (2') increments.
- d. These requirements are for all sewer lines/equipment installed within public ROW and in dedicated easements or which connect to District sewer mains.
- e. Whenever a compaction requirement value is specified herein, the optimum moisture content and Standard Proctor Density shall be determined in accordance with AASHTO T-99 for ninety-five percent (95%).
- f. Density Requirements in Trench – The Contractor shall obtain a Standard Proctor Density of ninety-five (95%) for the total depth of all trenches in open fields and in dedicated ROWs. Backfilling shall be done with good sound earth, sand or gravel, and no oil cake, bituminous pavement, concrete, rock or other lumpy material shall be used in the backfill unless these materials are scattered and do not exceed six inches (6") in any dimension and are not placed within one foot of the 2-1/2' limit. Material of perishable, spongy or otherwise improper nature shall not be used in backfilling and no material greater than four inches (4") in any dimension shall be placed within one foot (1') of any pipe, manhole or structure. Backfilling shall be accomplished in the zone in layers not to exceed three feet (3'). All backfill material shall be subject to the approval of the District's Engineer.
- g. Compacted Fill – Compaction shall be done by use of vibratory equipment, tamping rollers, pneumatic tire rollers or other mechanical tampers of the type and size approved by the

District 's Engineer. Hand tampers shall be used around all manholes and any surface structure. The backfill shall be placed in horizontal layers of such depths as are considered proper for the type of compacting equipment being used in relation to the backfill material being placed. Each layer shall be evenly spread, properly moistened and compacted to the specified density. Any damage to the pipe as a result of Contractor's operation shall be repaired and/or replaced.

h. Procedure at Street Zone – The top two and one-half-feet(2 ½') from finish street grade or ground surface, as the case may be, shall be compacted in horizontal layers not exceeding eight inches (8") in thickness, using approved hand pneumatic or mechanical type tampers to obtain a Standard Proctor Density of ninety-five percent (95%). Flooding and jetting are not permitted. From existing street grade to two and one-half-feet (2 ½') below street grade, the material for backfill may contain stones up to two inches (2") in diameter, in quantity not exceeding twenty percent (20%) of the volume where said coarse materials are well distributed throughout the finer material and the specified compaction can be obtained.

Low Pressure Air Test

Low pressure air tests in accordance with the latest version of UNI-BELL, UNI B-6 Specification, shall be used for testing of sewer main lines. Tests shall be performed with suitable equipment specifically designed for air testing sewers. The following procedure shall be used:

Flush and clean the sewer line prior to testing, thus serving to wet the pipe surface as well as clean out any debris. Plug the line at each manhole and all service connections with suitable test plugs. As a safety precaution, pressurizing equipment may include a regulator or relief valve set at ten (10) psi maximum to avoid over pressurizing and damaging an otherwise acceptable line.

Add air slowly until the internal air pressure of the sewer line is raised to four (4) psi gauge. At least two (2) minutes shall be allowed for the air temperature to stabilize before readings are taken and the timing started.

When the pressure has stabilized between 4.0 psig and 3.5 psi G, commence the test to determine the amount of time for pressure to drop by 0.5 psig. The test shall pass if the pipe pressure does not drop by more than 0.5 psig from the initial pressure reading within the time requirement listed in Table I.

Refer to Uni Bell, UNI-B-6 Specifications for testing when groundwater is present in Table I below.

Table I

Air Test, Based on Formulas from UNI-B-6-98

Specification Time (Min: Sec) Required for 0.5 PSIG Pressure Drop when Testing One Pipe Diameter Only

Length (Feet)	Pipe Diameter (Inches)													
	4	6	8	10	12	15	18	21	24	27	30	33	36	42
25	1:53	2:50	3:47	4:43	5:40	7:05	8:30	9:55	11:24	12:45	14:10	15:35	17:00	19:54
50	1:53	2:50	3:47	4:43	5:40	7:05	8:30	9:55	11:24	12:45	14:10	15:35	17:00	19:54
75	1:53	2:50	3:47	4:43	5:40	7:05	8:30	9:55	11:24	12:45	14:10	16:10	19:14	27:10
100	1:53	2:50	3:47	4:43	5:40	7:05	8:30	9:55	11:24	14:25	17:48	21:33	25:39	34:54
125	1:53	2:50	3:47	4:43	5:40	7:05	8:30	10:54	14:15	18:02	22:15	26:56	32:03	43:38
150	1:53	2:50	3:47	4:43	5:40	7:05	9:37	13:05	17:06	21:38	26:43	32:19	38:28	52:21
175	1:53	2:50	3:47	4:43	5:40	7:47	11:13	15:16	19:57	25:14	31:09	37:42	44:52	61:05
200	1:53	2:50	3:47	4:43	5:42	8:54	12:49	17:27	22:48	28:51	35:37	43:04	51:17	69:49
225	1:53	2:50	3:47	4:43	6:25	10:01	14:26	19:38	25:39	32:27	40:04	48:28	57:42	78:32
250	1:53	2:50	3:47	4:57	7:08	11:08	16:01	21:49	28:30	36:04	44:31	53:52	64:06	87:15
275	1:53	2:50	3:47	5:25	7:50	12:14	17:38	24:00	31:21	39:40	48:58	59:15	70:31	95:59
300	1:53	2:50	3:48	5:56	8:33	13:21	19:14	26:11	34:11	43:16	53:25	64:38	76:55	104:42
350	1:53	2:50	4:26	6:55	9:58	15:35	22:26	30:32	39:53	50:30	62:19	75:24	89:44	122:10
400	1:53	2:51	5:04	7:54	11:24	17:48	25:38	34:54	45:35	57:42	71:13	86:10	102:34	139:37
450	1:53	3:12	5:42	8:54	12:50	20:02	28:51	39:16	51:17	64:54	80:07	96:57	115:23	157:04

Vacuum Testing Manholes

The District reserves the right to require a vacuum test on all new manholes installed, particularly in areas where the groundwater level is high or where there are questions regarding the integrity of the new barrel sections. All manholes shall be vacuum tested in accordance with ASTM C1244. All lift holes and any pipes entering the manhole shall be plugged prior to a vacuum being drawn and the drop over a specified time determined. The test head shall be placed at the top of the manhole in accordance with the manufacturer's recommendations. A vacuum of ten inches (10") of mercury shall be drawn on the manhole, the valve on the vacuum line of the test head closed, and the vacuum pump shut off. The time shall be measured for the vacuum to drop to nine inches (9") of mercury. The manhole shall pass if the time for the vacuum reading to drop from ten inches (10") of mercury to nine inches (9") of mercury meets or exceeds the values indicated in Table II below.

Table II

Depth (Feet)	Diameter (Inches)									
	30	33	36	42	48	54	60	68	72	
	Time (Seconds)									
<= 8	11	12	14	17	20	23	28	29	33	
10	14	15	18	21	25	29	33	38	41	
12	17	18	21	25	30	35	39	43	49	
14	20	21	25	30	35	41	46	51	57	
16	22	24	39	34	40	46	52	58	57	
18	25	27	32	38	45	52	59	65	73	
20	28	30	35	42	50	63	65	72	81	
22	31	33	39	46	55	64	72	79	89	
24	33	38	42	51	59	64	78	87	97	
26	36	38	46	55	64	75	85	94	105	
28	39	42	49	59	69	81	91	101	113	
30	42	45	53	63	74	87	98	108	121	

WARRANTY AND ACCEPTANCE:

This section shall establish policy and procedures for the process by which a Contractor and/or Developer can transfer ownership and maintenance of sanitary sewer mains to the Berkeley Water and Sanitation District. The sanitary sewer mains must be eligible for acceptance by the District with respect to materials and work as set forth in the sanitary sewer sections of this manual.

Procedures

There shall be no implied ownership of sanitary sewer mains constructed by any entity other than the Berkeley Water and Sanitation Sewer District without strict adherence to the warranty and acceptance procedures as outlined in this section.

Although the District may operate the system to provide service to the users, the costs and responsibility of maintenance and repair of the systems will remain with the Developer and/or the Contractor until the mains have been granted final acceptance.

Responsibility

It shall be the responsibility of the Developer and/or the Contractor to make all requests and notifications to initiate warranty procedures and perform any follow-up correspondence and communication to gain acceptances.

Initial Acceptance Procedures:

Upon completion of paving, Contractor and/or Developer shall notify the District's Engineer of requests for Initial Acceptance inspection.

Contractor and/or Developer shall submit final stamped and bound compaction reports District, the District Engineer and the County.

The Contractor and/or Developer shall submit electronic format as-built drawings to District's Engineer for review. District's Engineer will compare as-builts against his field data and will make revisions if necessary, then return redlined as-builts to Contractor or Developer. Corrections will be made before the finalized as-builts are returned to the District.

Submit one (1) electronic copy with two (2) 22 x 34 and one (1) 11 x 17 prints.

The District's Engineer will conduct an Initial Acceptance inspection with District personnel, and the Developer/Contractor present. A punch list will be compiled by the District's Engineer of any deficient construction and transmitted to each party.

The Developer and/or Contractor will make necessary modifications to the sanitary sewer systems and notify the District's Engineer to make a follow-up inspection.

The District's Engineer will conduct a follow-up inspection with District personnel, Developer and/or Contractor to confirm modifications have been completed.

The District's Engineer will write a letter of recommendation to District Manager.

The District will confirm that all fees owed to the District are current, as-builts are in their possession, and that they have received their copy of the compaction report.

The District will notify the Developer or Contractor in writing that the initial acceptance period is in effect.

The Contractor or Developer is responsible for all repairs and maintenance of the sanitary sewer mains they have constructed for a period of two (2) years from the effective date of Initial Acceptance.

Prior to Initial Acceptance walk-through, the Contractor or Developer shall jet clean the entire sanitary sewer system and pump out at the plugged manhole.

The Contractor and Developer will be held responsible for the proper functioning of the lines for up to two (2) years from the date of initial acceptance of the lines by the District. Any malfunction during this period of guarantee shall be remedied by the Contractor to the satisfaction of the District's Engineer at no expense to the District.

The anticipated date of Final Acceptance will be indicated in the conditions of the Initial Acceptance Letter. The Developer shall be responsible for contacting the District for final inspection and Final Acceptance.

Settlement

The Contractor will be responsible for repairing or complete replacement of any deterioration or settlement of the pipe trenches and associated street surfaces. Notification of the required repairs will be issued by the District. All costs of repairs and all liability, as a result of surface deterioration or settlement, shall be the responsibility of the Contractor. The two-year Warranty Period shall be extended for the entire project to cover future settlement deterioration until the Project as a whole shows no signs of settlement deterioration.

Final Acceptance Procedures:

After approximately twenty-three (23) months have passed following the effective date of Initial Acceptance, the Developer and/or Contractor shall contact the District's Engineer to schedule a Final Acceptance walk-through inspection.

District's Engineer conducts Final Acceptance inspection with District personnel, Developer, and/or Contractor present. A punch list of deficient items will be compiled by the District's Engineer and transmitted to each party.

Developer and/or Contractor will make necessary modifications to the items contained in the punch list and notify the District's Engineer to make a follow-up inspection.

District's Engineer conducts follow-up inspection with District personnel, Developer and/or Contractor to confirm modifications have been completed.

District's Engineer writes letter of recommendation to District Manager.

If all outstanding issues have been satisfied and Developer has provided a Bill of Sale to the District, the District will notify the Contractor and/or Developer in writing of the effective date of Final Acceptance.

The District will then have the responsibility of ownership and maintenance of the sewer mains from the effective date of Final Acceptance forward.

As-Built Submittal Procedures

As-builts shall verify the location, size, type, class and elevation of all pipes (water, sanitary and storm) manholes, water service lines, fire lines, curb stop boxes, meter pits, valves, fire hydrants, sewer laterals, and infrastructure shown on the construction plans. This will include those improvements outside of public ROW and off-site improvements

The drawings and electronics will be revised to show all As-built horizontal locations to within one foot (1') and all vertical elevations to within 0.1'.

The Certification Block shall appear on the cover sheet of each set of drawings.

As-builts shall provide Northing and elevation for two (2) section corners adjacent to the site.

If the improvements for a project are constructed in phases, as-built drawings will be submitted at the completion of each phase.

Hard Copies

- Prior to Final As-Builts, submit one (1) paper copy to the Berkeley Water & sanitation District
- After addressing redline comments and prior to Initial Acceptance, provide to the District:
 - One (1) 22" x 34" full size and one (1) 11" x 27" paper sealed and signed sets for the District.
 - Electronics as identified below.

Electronics

- Submittals may be emailed or submitted on a portable drive or CD
- All drawings are to be in Auto CAD
- Provide PDFs of the entire plan set. PDF each sheet individually. Name the PDF by using the drawing name and date of completion
- All PDF drawings must be to scale

Contents of the Electronic File

- All information must be contained in two (2) folders; labled "DRAWINGS" and "PDFs"
- The "DRAWINGS" folder shall include all AutoCAD drawings for the project

Initial Acceptance will not be granted until the As-Builts are received by the District.

- APENDIX 1 – GREASE TRAP DESIGN

EXHIBITS

- Certification Block for As-Built Drawings
- Approval Block
- Certification of Initial Acceptance
- Certification of Final Acceptance

SANITARY SEWER SYSTEM DETAILS

- General Sanitary Sewer Notes
- Typical Trench Section Pipe Protection
- Concrete sewer Encasement
- Metallic Detection Tape
- Steel Marker Post
- Sanitary Sewer Bore Casing
- Bulkhead Construction
- Sanitary Sewer Wye Branch Connection for Main Depth Less than 12'
- Sanitary Sewer Wye Branch Connection for Main Depth Greater than 12'
- Sanitary Sewer Manhole (CIP Base)
- Sanitary Sewer Manhole (Precast Base)
- Confined Space Safety Tag
- Standard Drop Manhole
- Manhole Base and Deflector
- Manhole Platform
- Manhole Ring and Cover with Lift Slot
- Two-way Cleanout
- Sanitary Sewer Pipe Bedding
- Sewer Tapping

APPENDIX 1 – GREASE TRAP DESIGN

Grease Trap Design:

Oil and Grease Interceptor Specifications

Grease Interceptor Definition

A grease interceptor is a device designed and installed to separate and retain grease and other related undesirable matter from normal wastes and permit normal sewage or liquid wastes to discharge into a wastewater collection system by gravity. Interceptors differ from fixture grease traps in that, in addition to preventing the back passage of gases from drainage systems into a building, they also protect the drainage and wastewater collection systems from substances that might plug, block, or otherwise be harmful to those systems.

Grease Interceptor Installation Requirement Criteria

Grease interceptors shall be required for all food preparation establishments which would contribute or cause to contribute, directly or indirectly, any water or wastewater which contains oil and grease, including but not limited to, restaurants, cafeterias, cafes, and fast food establishments. Additionally, grease interceptors shall be required for all schools, fraternal organizations, churches, hospitals, and daycare centers which have the capability to engage in food preparation. The grease retaining capacity of each grease interceptor in pounds of grease shall be equal to twice the rate the flow capacity in gallons per minute of wastewater so that the interceptor shall remove and retain ninety (90) percent of the grease discharged into it up to its required capacity of accumulated grease.

Exceptions to the grease interceptor requirement shall be those facilities granted a written variance by the District's Engineer, following approval of the plan review process. Variances shall apply strictly to the named facility owner/operator located at the named facility address.

Approved Drawings of Grease Interceptor

One complete set of plans and specifications, including complete architectural and plumbing floor plans, shall be submitted the Berkeley Water and Sanitation District's Engineer for approval prior to construction. These plans must include the following information:

- A diagram showing all locations and routes of all wastewater lines
- Proposed interceptor size and type
- Location of the grease interceptor being installed outside the building

Grease Interceptor Design Criteria

Each business establishment, for which a grease interceptor is required, shall have an interceptor which serves only that establishment. The design of oil and grease interceptors shall be constructed in accordance with the design approved by the Berkeley Water and Sanitation District and shall have a minimum of two (2) compartments with fittings designed for grease retention. The minimum size for any grease interceptor shall not be less than 800 gallons.

There shall be an adequate number of manholes to provide access for cleaning all areas of an interceptor; a minimum of one (1) per ten (10) feet of interceptor length. Manhole covers shall be gastight in construction having a minimum opening dimension of twenty-four (24) inches. In addition, an effluent sampling box shall be provided on all grease interceptors. In areas where traffic may exist, the interceptor shall be designed to have adequate reinforcement and cover.

Grease Interceptor Sizing Criteria

The sizing criteria shall be in accordance with Metro Wastewater's Quality Control Procedures for grease interceptor sizing.

Basic Formula:

(Turn-Over Rate) x (Categorical Use Factor) x 2.5 (gallons of water) x (Seating Capacity)

The varying sizing applications are broken down into the following categories and formulas:

Category A – Restaurants/Cafeterias

Full or limited service with the capability to serve or prepare 100 meals per day.

Plumbing fixtures: one pot sink, one 2 or 3 compartment sink, one hand sink, one mop sink, one floor sink, one dishwasher, and one garbage disposal that is directed to the grease interceptor.

Equipment: one grill, one fryer, one to three ovens/

Formula: $2.0 \times 1.25 \times 2.5 \times \text{Seating}$

For each additional garbage grinder and dishwasher that is to be directed to the Grease Interceptor there will be a factor of .25 added to the Categorical Use Factor (C.U.F.). For each additional "wok" stove, deep fryer, and grill, there will be a factor of .50 added to the categorical factor.

Category B – Hospitals, Schools, Institutions, and Care Facilities

Formula:

Hospitals/Schools

2.0 x .75 x 2.5 x bed usage or seating

Institutions/Care Facilities

2.0 x 1.0 x 2.5 x seating or bed usage

These formulas will be adjusted by the following when necessary:

A value of .25 will be added to the Categorical Use Factor for each dishwasher or garbage disposal directed to the Grease Interceptor above the number of one each.

A value of .50 will be added to the Categorical Use Factor for each additional deep fryer or grill above the number of one each.

Category C – Deli Stores and Super Markets with meat cutting capabilities and/or bakeries, retail and wholesale bakery facilities and butcher shops

Formula: (Hours of Operation) x 4.0 x 10

For each of the following conditions a factor of .50 is to be added to the Categorical Use Factor value of 4.0 when dealing with meat cutting:

1. More than one floor drain
2. Complete cooking of meats

When dealing with retail types of bakeries or Super Markets that have bakery facilities in addition to deli and/or meat cutting, the bakery shall be sized separately using the same formula as above with the deletion of the .50 adjustment of an addition of 1.5 to the Categorical Use Factor when dealing with bakeries that are wholesale only or are of the industrial classification.

Category D – Food Courts or “Common” Interceptors

Each case shall be sized by separating each of the potential contributors into its own category then combining the operations for a total interceptor size.

Category E – Commissaries, Commercial Kitchens, and Caterers

Each facility must be sized on an individual, case by case basis. However, it should be noted that the minimum acceptable size for a commercial kitchen shall be 1,500 gallons.

Category F – Food Manufacturing Types

Each case is evaluated separately. Whenever a manufacturing operation is evaluated, it must be noted that a “Control Manhole” will be required in most cases in addition to a minimum of 1500 gallons.

Grease Interceptor Location

Each grease interceptor shall be so installed and connected that it shall be at all times easily accessible for inspection, cleaning, and removal of the intercepted grease. The use of ladders and removal of bulky equipment will result in violation of accessibility. The interceptor shall be located as close to the source as practical, however, it must be outside the facility served. In no case shall a grease interceptor be installed in any part of a building where food is handled. The locations of any grease interceptor shall meet the approval of the District’s Engineer.

Grease Interceptor Maintenance and Plumbing Schedules

The owner and lessee are jointly responsible for the cleaning of the interceptor. It shall be maintained in efficient operating condition by the removal of accumulated grease and solids. The removal of grease and solids shall be performed before the capacity of the interceptor is exceeded. The owner and/or lessee shall conduct, on a monthly basis, an inspection on each interceptor. Records of these inspections must be kept on site for a minimum of three (3) years.

All users connected to grease interceptors are required to do a complete pump out their interceptors quarterly; or, when the total accumulation of surface oil and grease (including floating solids) and settled solids reaches twenty-five (25%) of the grease interceptor’s overall liquid depth; or, when approximately seventy-five (75%) volume retention whichever occurs first. Inspections of the grease interceptors by the Berkeley Water and Sanitation District will determine if this frequency needs to be increased to control the amounts of oil and grease entering the wastewater collection system.

In the event that an interceptor fails, the Berkeley Water and Sanitation District’s specifications, the owner/lessee shall have ten (10) days to bring the facility into compliance. If the interceptor still fails after the second inspection, Berkeley Water and Sanitation District shall contract with an approved contractor to bring the facility into compliance. The cost of the work shall be billed

to the owner/lessee of the facility. Failure to pay for the resulting bill shall result in additional enforcement actions being taken.

Inspection of Grease Interceptors

The Berkeley Water and Sanitation District will inspect all grease interceptors in the Berkeley Water and Sanitation District's service area. The Berkeley Water and Sanitation District's wastewater collection system will inventory all grease interceptors in their service area and document the inspections of these interceptors. The inspection criteria shall include however and is not limited to the following:

- Location and accessibility
- Interceptor capacity
- Identification of inlet and outlet compartments, where applicable
- Identification of inlet and outlet piping systems, where applicable
- Identification of missing and/or damaged system
- Identification of bacterial uses
- Approximate capacity (depth) of accumulated solids and grease layer
- Verification of maintenance records

Once the grease interceptors in the service area are identified, the interceptors will be classified into two (2) categories:

Problem or Significant Grease Interceptors

The facilities connected to these grease interceptors contribute significant amounts of animal/vegetable oil and grease to the wastewater system. These grease interceptors will be inspected at a frequency of at least once every one (1) to three (3) months.

Non-significant Grease Interceptors

The facilities connected to these grease interceptors do not contribute significant amounts of animal/vegetable oil and grease to the wastewater collection system. These grease interceptors will be inspected at a frequency of every three (3) to six (6) months.

Biological Treatment

The introduction of emulsifying agents such as chemicals, solvents, or enzymes either directly or indirectly into the grease interceptor, other than what is considered typical business operational practices such as dishwashing, or sanitation, is strictly prohibited. The use of biological treatment shall not be a substitute for the pumping or cleaning of the grease interceptor at the frequency

required by the Berkeley Water and Sanitation District. The use of bacteria is not prohibited by the Berkeley Water and Sanitation District; however, these products are highly discouraged due to their potential to emulsify the grease, moving it through the interceptor and into the waste stream where serious damage can occur to the wastewater collection system.

Existing Sources Not Connected to Grease Interceptor

Existing sources not connected to grease interceptors and which contribute significant amounts of oil and grease will be identified through inspection of the wastewater collection systems by Berkeley Water and Sanitation District. Once these sources are identified, they will be required to implement Best Management Practices Plans (BMPP's) to keep oil and grease out of the wastewater collection system. Examples of BMPP's include:

1. Scrape food from plates into a garbage can.
2. Pre-wash plates by spraying them off with cold water over a small mesh catch basin positioned over a drain. This catch basin should be cleaned into a garbage can as needed.
3. Pour all liquid oil and grease from pots and pans into a waste grease bucket stored at the pot-washing sink. Heavy solids build up of oil and grease on pots and pans should be scraped off into a waste grease bucket.
4. Other kitchen practices identified by Berkeley Water and Sanitation District which will decrease the point source discharge of oil and grease.

If the BMPP's are not successful at the facility and the facility continues to contribute significant amounts of oil and grease to the wastewater collection system, as documented by field inspections, then the facility will be required to install an adequately sized grease interceptor as determined by the sizing criteria in this document.

Abandoned Grease Interceptors

Abandoned grease interceptors shall be pumped and filled as required for abandoned sewers and sewage disposal facilities.

Oil and Grease Trap Specifications

Grease Trap Definition

A grease trap is a small reservoir built into the wastewater piping a short distance from the grease producing area. Baffles in the reservoir retain the wastewater long enough for the grease to congeal and rise to the surface. The grease can then be removed and disposed or recycled.

Grease Trap Requirements

Users may receive approvals to install an in-floor or under-the-sink grease traps for small volume facilities, provided: 1) the grease trap is no more than fifty (50) gallons in liquid/operating capacity; 2) proper methods are implemented (e.g. absorb liquids into soil form and dispose into trash, collect grease in container and recycle, or contract a grease hauler) and 3) detailed records on these activities are maintained and are available for review upon request.

Grease Trap Sizing

The size of the trap depends upon the number of fixtures connected to it. The following table provides criteria for sizing grease traps:

Total number of fixtures connected	Required rate of flow, gpm	Grease retention capacity, lbs
1	20	40
2	25	50
3	35	70
4	50	100

Grease Trap Maintenance

Grease traps are required to be cleaned weekly, unless it is determined through Berkeley Water and Sanitation District inspections that the frequency can be reduced. If the facility wished to conduct self-cleaning of the grease trap, the facility must bail out any water in the trap to facilitate cleaning. Then they must remove the free floating grease, scraping the sides and lid, and recycle or dispose of the grease in the trash. The bailed water may return to the grease trap after it has been cleaned.

Grease Trap Inspections

In the event that a trap fails the Berkeley Water and Sanitation District's specifications, the owner/lessee shall have ten (10) days to bring the facility into compliance. If the trap still fails after the second inspection, Berkeley Water and Sanitation District shall contract with an approved contractor to bring the facility into compliance. The cost of the work shall be billed to the owner/lessee of the facility. Failure to pay for the resulting bill shall result in additional enforcement actions being taken.

Grease traps will be inspected at the frequency as grease interceptors. The inspection criteria of grease traps will be based upon the following:

Percent of Trap Filled	Trap Condition
25	Adequate
25 – 50	Poor Need Pumping
>50	Needs Immediate Pumping

Violations incurred by grease traps will be subject to the same enforcement actions as those of grease interceptors; including but not limited to, the removal of the grease trap and a requirement to install a properly sized grease trap.

Typical Grease Interceptor And Sample Port Piping Layout

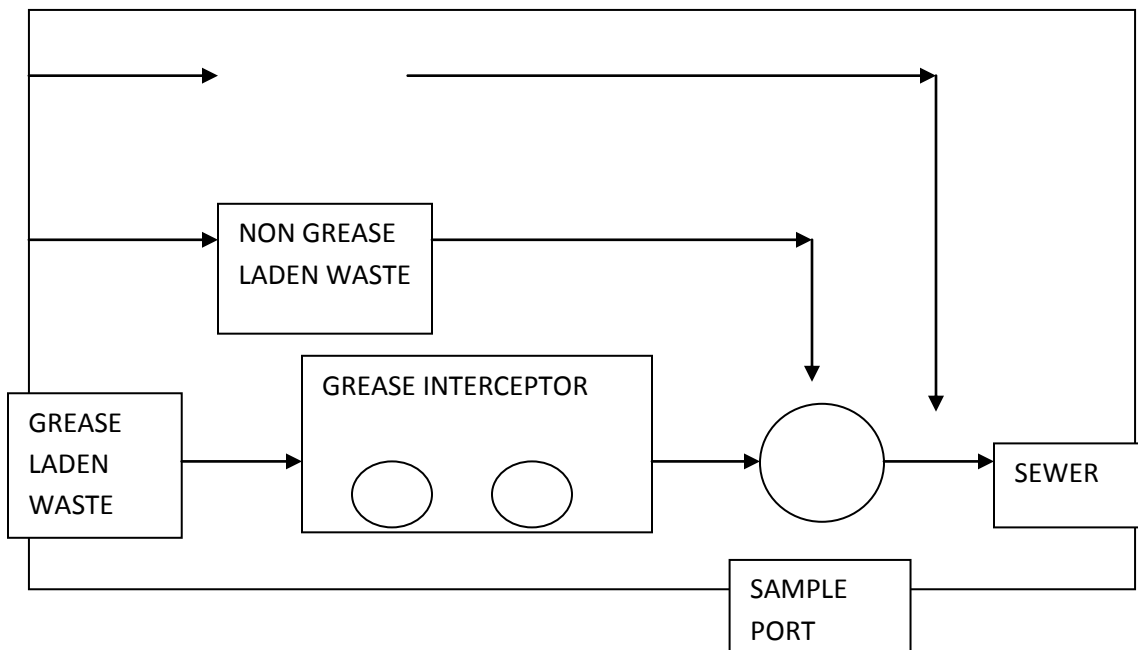

NOTES:

1. The Grease Laden Wastewater line must include a minimum six inch vertical drop in the sample port.
2. The Non Grease Laden Wastewater line must flow through the bottom of the sample port.
3. All wastewater, except the restroom waste may flow through the grease interceptor.
4. The sample port cannot hold water.

Typical Grease Interceptor and Sample Port Installation

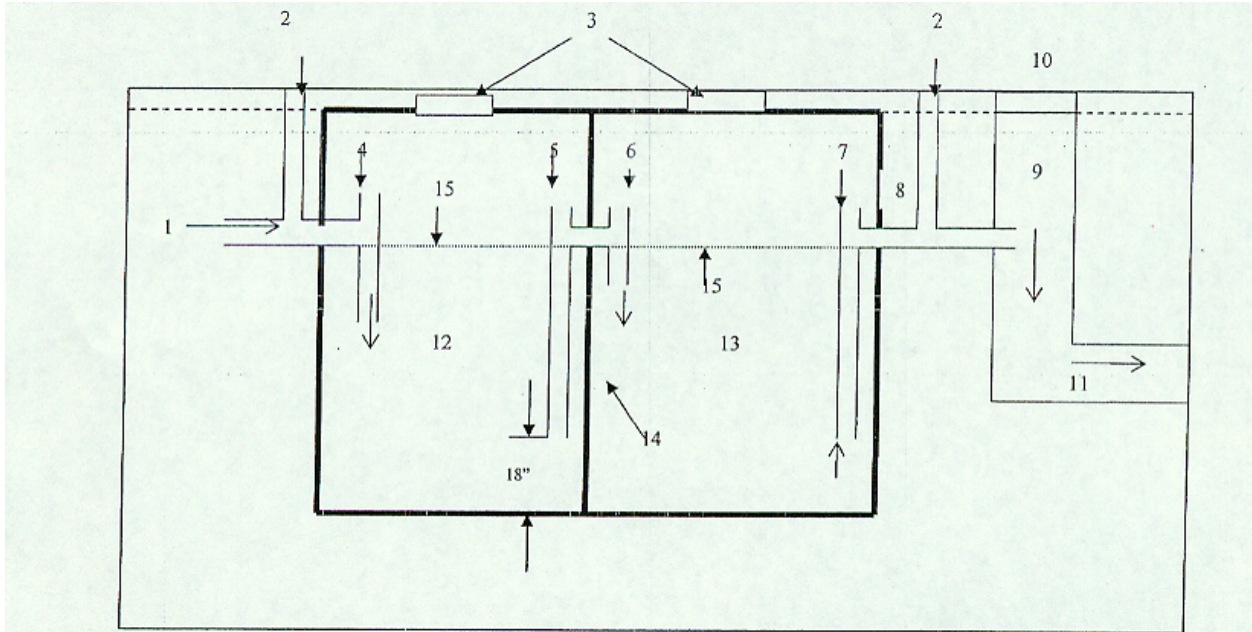

SIDE VIEW

1. Influent Line
2. Vents
3. Minimum 24 inch opening with a ring and lid.
4. Primary chamber inlet piping (must extend 1 foot below the operating level)
5. Primary chamber outlet piping (must extend 1 foot below the operating level)
6. Secondary chamber inlet piping (must extend 1 foot below the operating level)
7. Secondary chamber outlet piping (must be extended 18" from the bottom of the chamber)
8. Grease interceptor discharge line
9. Sample port (minimum 10" diameter, provide at least a 6" vertical drop for the grease interceptor discharge)
10. Sample port ring and lid
11. Sample port discharge line to the sewer
12. Primary chamber
13. Secondary chamber
14. Baffle (must be sealed)
15. Grease interceptor operating level

NOTE:

1. All wastewater except restroom waste must flow through the sample port.
2. The sample port cannot hold water.

7 INSPECTION FLOW CHART

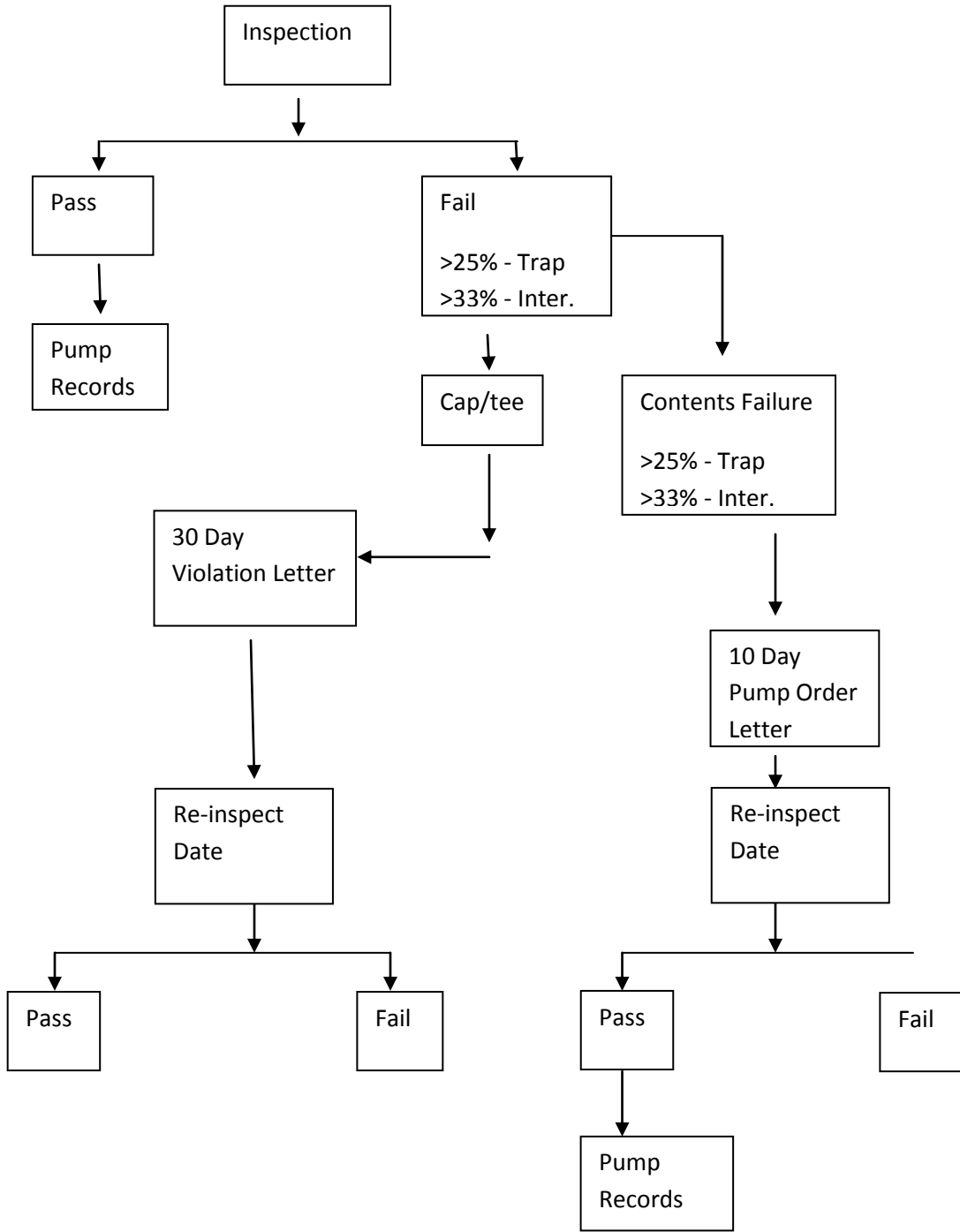

Certification Block for As-built Drawings

The responsibility professional engineer, licensed in the State of Colorado, for the project shall state:

“I hereby affirm that the public improvements (name of subdivision or project) have been constructed in compliance with the construction plans approved by the District and revised as noted to reflect the “As-built” conditions.”

Name, P.E. Date

Approval Block

<p>ENGINEERING REVIEW: BERKELEY WATER AND SANITATION DISTRICT</p> <p>REVIEW IS FOR GENERAL COMPLIANCE WITH DISTRICT PROCTICES, POLICIES AND ENGINEERING STANDARDS. THE DISTRICT IS NOT RESPONSIBLE FOR THE CORRECTNESS OR DESIGN, DIMENSIONS, DETAILS, QUANTITIES OR DESIGN SAFETY.</p> <p>_____ DISTRICT MANAGER DATE</p>
--

CERTIFICATE OF INITIAL ACCEPTANCE

TO: _____

DATE: _____

PROJECT NO.: _____

PROJECT TITLE: _____

This is to advise you that as inspection of the referenced work has been made. All work and materials were found to be satisfactory. Therefore, the work is considered to be complete in accordance with the approved plans, specifications, and contract documents.

THE TWO (2) YEAR WARRANTY PERIOD SHALL BEGIN AS OF: _____

Please coordinate with the District for the Final Acceptance walk-through inspection twenty-three (23) months after the date of the Initial Acceptance or no later than: _____

Berkeley Water & Sanitation District

By: _____

Title: _____

CERTIFICATE OF FINAL ACCEPTANCE

TO: _____ DATE: _____

PROJECT NO.: _____

PROJECT TITLE: _____

This is to advise you that as inspection of the referenced work has been made. All work and materials were found to be satisfactory. Therefore, the work is considered to be complete in accordance with the approved plans, specifications, and contract documents.

THIS PROJECT SHALL BE ACCEPTED AS OF: _____

Berkeley Water & Sanitation District

By: _____

Title: _____

1. ALL MATERIALS AND WORKMANSHIP FOR SANITARY SEWER CONSTRUCTION SHALL CONFORM TO THE LATEST BERKELEY WATER AND SANITATION DISTRICT STANDARDS AND THE LATEST CITY AND COUNTY OF DENVER, DEPARTMENT OF PUBLIC WORKS, STORM DRAINAGE AND SANITARY SEWER CONSTRUCTION DETAILS AND TECHNICAL SPECIFICATIONS, WASTEWATER MANAGEMENT DIVISION STANDARD DETAILS.
2. AT LEAST 5 DAYS PRIOR TO THE START OF CONSTRUCTION, A PRE-CONSTRUCTION MEETING WILL BE HELD AT THE DISTRICT'S OFFICE AND ATTENDED BY THE CONTRACTOR AND REPRESENTATIVES OF THE OTHER APPROVING AGENCIES. IT WILL BE THE RESPONSIBILITY OF THE CONTRACTOR TO CONTACT THE DISTRICT ENGINEER TO SCHEDULE THIS MEETING.
3. THE CONTRACTOR TO VERIFY THE HORIZONTAL AND VERTICAL LOCATION OF ALL TIE IN POINTS AND PROVIDE THE DATA TO THE DISTRICT ENGINEER PRIOR TO CONSTRUCTION.
4. THE CONTRACTOR WILL IDENTIFY THE HORIZONTAL AND VERTICAL LOCATION OF ALL EXISTING UTILITIES PRIOR TO CONSTRUCTION. THE CONTRACTOR WILL REPORT ANY DISCREPANCIES TO THE ENGINEER IMMEDIATELY AND PRIOR TO CONSTRUCTION.
5. THE CONTRACTOR SHALL HAVE IN THEIR POSSESSION AT ALL TIMES ONE SIGNED COPY OF PLANS APPROVED BY THE BERKELEY WATER AND SANITATION DISTRICT AND THE DISTRICT ENGINEER. THESE PLANS WILL ALSO INCLUDE ALL ADDENDUMS OR REVISIONS WHICH HAVE BEEN REVIEWED AND APPROVED BY THE BERKELEY WATER AND SANITATION DISTRICT AND THE DISTRICT ENGINEER.
6. PRIOR TO THE START OF WORK WHERE THE NEW SEWER MAIN IS TO BE INSTALLED INTO EXISTING DISTRICT SEWER SYSTEMS, THE NEAREST MANHOLE TO THE POINT OF TIE-IN SHALL BE PLUGGED WITH A PLUMBER'S PLUG ON THE INLET SIDE BY THE CONTRACTOR. THIS PLUG SHALL REMAIN IN PLACE UNTIL INITIAL ACCEPTANCE BY THE DISTRICT. ITS PURPOSE SHALL BE TO PREVENT MUD, WATER OR OTHER MATERIALS FROM ENTERING THE LINE DURING CONSTRUCTION. THE CONTRACTOR SHALL BE RESPONSIBLE FOR PUMPING AND CLEANING THESE MANHOLES AND REMOVING THE PLUG WHEN SO INSTRUCTED BY THE DISTRICT.
7. ALL DIRECT BURY SEWER MAINS SHALL BE PVC, ASTM D-3034, SDR35 OR APPROVED EQUIVALENT.
8. SEWER LINES SHALL BE 10 FEET FROM WATER LINES EXCEPT WHEN CROSSING EACH OTHER. FOR SEWER LINES WHICH CROSS LESS THAN 1 1/2 FEET VERTICALLY FROM WATER LINES, THE CLOSEST SANITARY SEWER JOINT SHALL BE A MINIMUM OF 6 FEET FROM THE CROSSING.
9. ALL MANHOLES SHALL BE WATER TIGHT, WET PRECAST CONCRETE, A MINIMUM OF 48 INCH IN DIAMETER WITH CONCENTRIC CONE, 24 INCH CAST IRON RING (8" DEPTH) AND COVER, UNLESS OTHERWISE SPECIFIED. CONCRETE ADJUSTMENT RINGS SHALL BE USED FOR ADJUSTMENT TO MATCH FINAL PAVEMENT ELEVATIONS AND SET IN FLEXIBLE BUTYL RUBBER CAULKING TO OBTAIN A WATER TIGHT SEAL. CONCRETE ADJUSTMENT RINGS SHALL BE 4" MINIMUM IN DEPTH TO ELIMINATE MULTIPLE JOINTS.

BERKELEY WATER AND SANITATION DISTRICT

**GENERAL SANITARY SEWER
NOTES**

Scale: *NONE* | Date: *APRIL 2019*

Revised: | Detail: *1*

10. PIPE BEDDING SHALL BE CLASS "B" AND SHALL CONFORM TO ASTM C-33 OR AASHTO D-448 GRADATION NO. 6 OR NO. 67. SQUEEGEE BEDDING IS PREFERRED. BEDDING DEPTH SHALL BE 6" UNDER AND AROUND THE SIDES OF THE PIPE AND 12" OVER THE PIPE. CONSOLIDATION IN PIPE ZONE SHALL BE BY HAND TAMPING.

11. ALUMINUM FOIL WARNING TAPE SHALL BE USED FOR ALL NEW DIRECT BURY SEWER MAINS. THE TAPE WILL BE INSTALLED 2' BELOW FINISHED GRADE. TAPE MUST BE GREEN IN COLOR.

12. FERNCO **STRONGBACK**[®] RC SERIES PIPE COUPLINGS WILL BE REQUIRED FOR PIPE AND LATERAL SERVICES. APPROPRIATE CONCRETE CRADLES SHALL ALSO BE INSTALLED AROUND FERNCO STRONGBACK.

13. TRENCH BACKFILL CANNOT HAVE ROCKS LARGER THAN 4" IN DIAMETER.

14. IF GROUND WATER IS ENCOUNTERED, CUT-OFF WALLS OR FLASH FILL SHALL BE INSTALLED AROUND THE PIPE EVERY 300'+/- AND 10' FROM EACH SIDE OF MANHOLE. FLASH FILL MUST MEET ADAMS COUNTY STANDARDS.

15. IF GROUNDWATER, UNSUITABLE OR UNSTABLE SOILS BE ENCOUNTERED, A SUB-BEDDING BASE DEPTH OF 18" MINIMUM OF 2" MINIMUM DIAMETER CRUSHED ROCK, SURROUNDED AND COVERED BY GEOTEXTILE FABRIC SHALL BE INSTALLED.

16. IF SEWAGE BYPASS PUMPING IS NECESSARY, THE CONTRACTOR WILL SUPPLY AND MONITOR THE PUMP DURING THE ENTIRE PUMPING PERIOD. A BACK-UP PUMP WILL BE ONSITE FOR USE IF NECESSARY. BYPASS HOSE SHALL BE PROTECTED FROM TRAFFIC DAMAGE USING APPROVED APPARATUS FOR ALL SEWAGE BYPASS PUMPING. THE CONTRACTOR WILL HAVE CONTINUOUS ON SITE MONITORING OF PUMPING OPERATIONS.

17. PRIOR TO THE INITIAL ACCEPTANCE AND FINAL ACCEPTANCE WALK-THROUGH, THE CONTRACTOR/DEVELOPER SHALL JET CLEAN THE ENTIRE NEW SANITARY SEWER SYSTEM AND PUMP OUT AT THE PLUGGED MANHOLE AND DISPOSE OF JET-CLEANING WATER OFFSITE IN ACCORDANCE WITH LATEST CDPHE STANDARDS. AFTER CLEANING THE NEW SEWER MAIN, THE CONTRACTOR WILL DUMP CLEAN WATER DOWN THE NEW SANITARY SEWER MAIN PRIOR TO THE VIDEO INSPECTION. THE CONTRACTOR WILL PUMP OUT AND DISPOSE OF WATER AT A DISTRICT APPROVED MANHOLE. CONTRACTOR WILL VIDEO THE NEW SANITARY SEWERS BEFORE BOTH ACCEPTANCES BY THE DISTRICT AND PROVIDE VIDEOS TO THE DISTRICT FOR REVIEW.

18. ABANDONING PROCEDURES:

FOR SANITARY SEWER MAINS TO BE ABANDONED - PLACE MECHANICAL PLUG IN THE PIPE AND FILL 5' OF ABANDONED SEWER LINE WITH CONTROLLED LOW SLUMP MATERIALS (CLSM).

FOR SANITARY SEWER MANHOLES TO BE ABANDONED - REMOVE CAST IRON COVER, RIM, CONCRETE ADJUSTMENT RINGS AND CONE. FILL LOWER 1/3 OF MANHOLE WITH CLSM AND REMAINDER OF MANHOLE WITH CLEAN BACKFILL. SALVAGE MANHOLE COVER AND RIM.

THE MANHOLE COVERS AND RIMS ARE THE PROPERTY OF THE DISTRICT. CONTACT DISTRICT ENGINEER FOR DISPOSITION.

BERKELEY WATER AND SANITATION DISTRICT	
GENERAL SANITARY SEWER NOTES-CONT.	
Scale: <i>NONE</i>	Date: <i>APRIL 2019</i>
Revised:	Detail: <i>2</i>

19. ALL MANHOLE AND SANITARY SEWER MAIN TESTING SHALL BE WITNESSED BY A REPRESENTATIVE OF THE DISTRICT. A MINIMUM OF 48 HOURS ADVANCED NOTICE IS REQUIRED PRIOR TO TESTING.

20. ALL MATERIALS AND TESTING TO ADHERE TO LATEST APPLICABLE ASTM STANDARDS.

21. CONSTRUCTION STAKING STATIONING TO USE CONSTRUCTION PLAN STATIONING.

22. SANITARY SEWER SERVICE LOCATION AND ELEVATIONS OUT OF BUILDINGS INFORMATION WILL BE PROVIDED TO DISTRICT ENGINEER PRIOR TO CONSTRUCTION OF SERVICE LINE.

BERKELEY WATER AND SANITATION DISTRICT	
GENERAL SANITARY SEWER NOTES-CONT.	
Scale: <i>NONE</i>	Date: <i>APRIL 2019</i>
Revised:	Detail: <i>3</i>

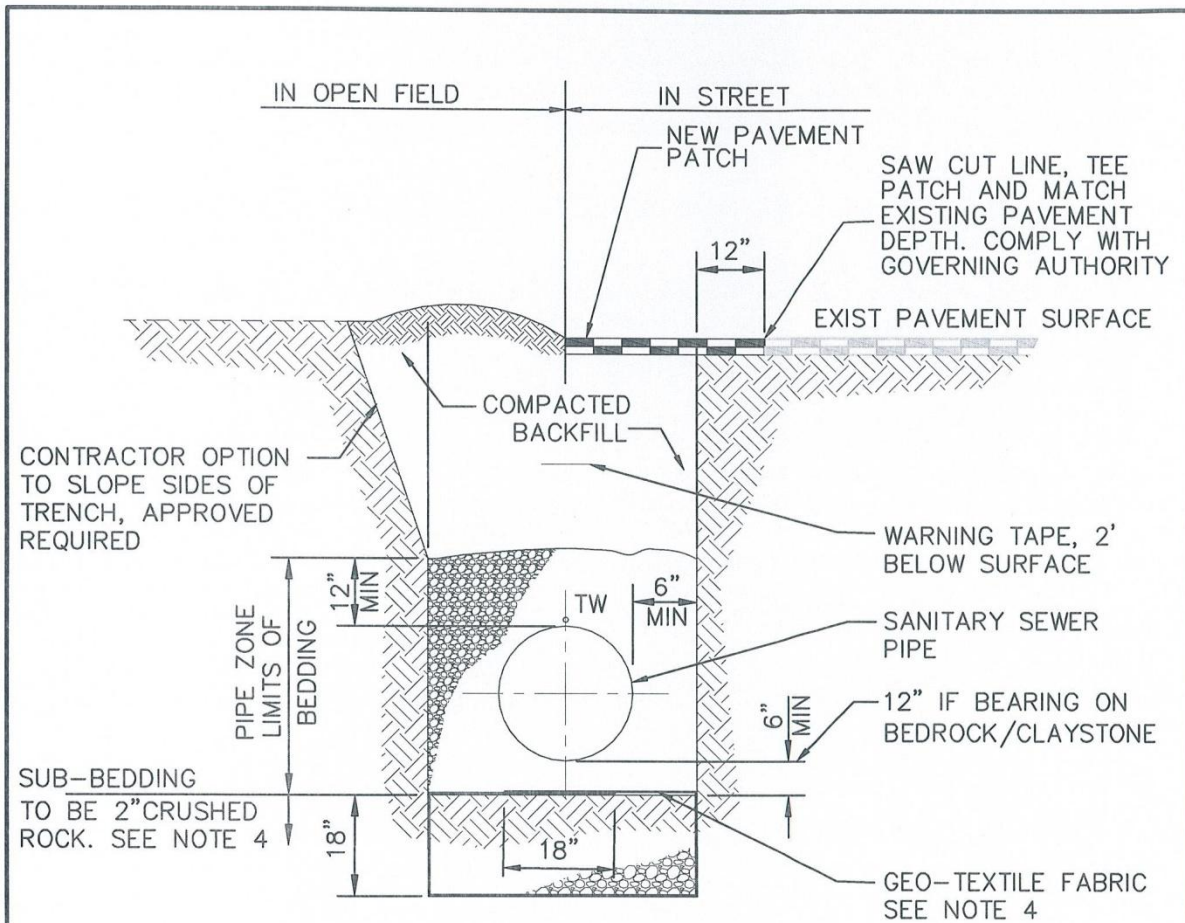

PIPE BEDDING AND BACKFILL NOTES:

1. TRENCH WALLS TO BE SUPPORTED AS REQUIRED BY OSHA.
2. TRENCH BACKFILL SHALL CONTAIN NO ROCKS/STONES LARGER THAN 4" IN DIAMETER.
3. HAND COMPACTION IS REQUIRED AROUND ALL MANHOLES, DISTRICT APPURTENANCES, AND ALL OTHER GROUND OBSTACLES.
4. IF GROUND WATER IS PRESENT OR KNOWN TO BE, OR UNSUITABLE/UNSTABLE SOIL IS ENCOUNTERED, SUB-BEDDING AND GEO-TEXTILE FABRIC IS REQUIRED.

BERKELEY WATER AND SANITATION DISTRICT	
TYPICAL TRENCH SECTION PIPE PROTECTION	
Scale: <i>NONE</i>	Date: <i>APRIL 2019</i>
Revised:	Detail: <i>4</i>

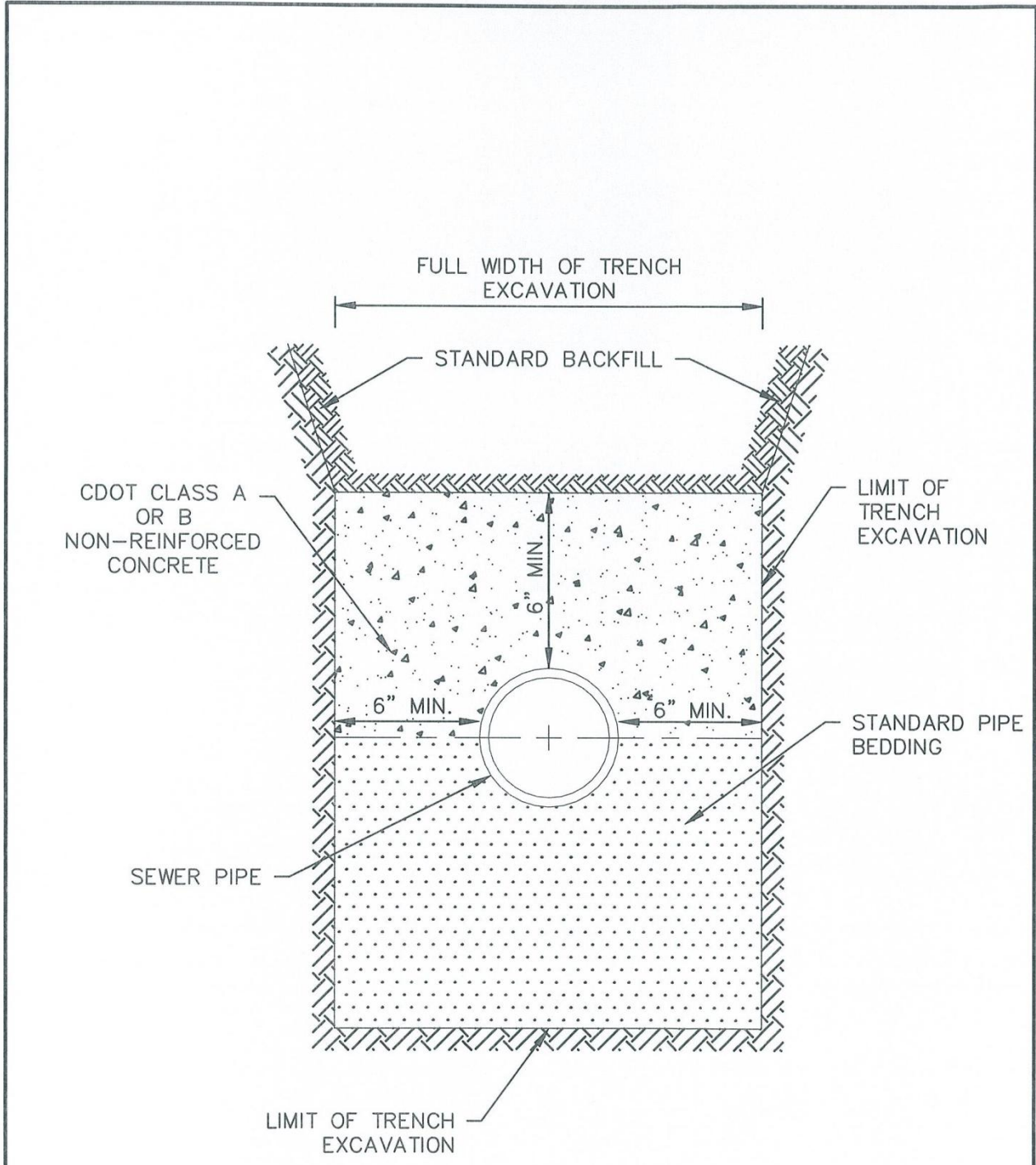

BERKELEY WATER AND SANITATION DISTRICT	
CONCRETE PIPE SADDLE	
Scale: <i>NONE</i>	Date: <i>APRIL 2019</i>
Revised:	Detail: <i>5</i>

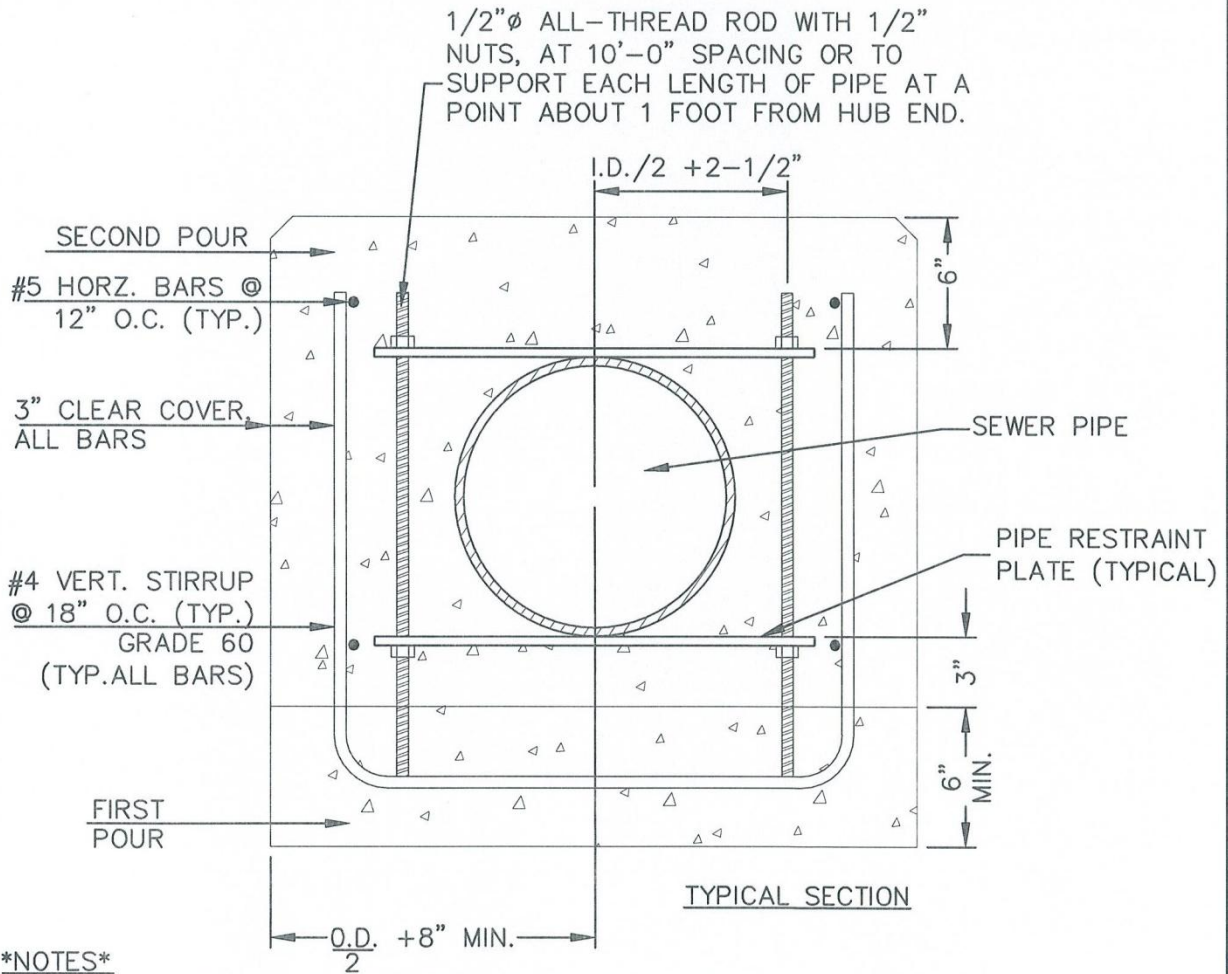
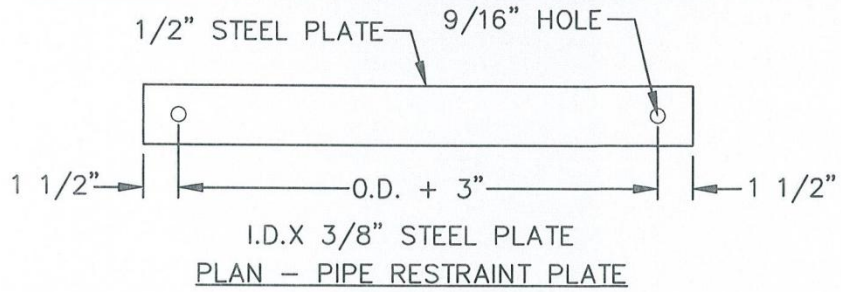

NOTES

1. MINIMUM LENGTH OF REINFORCEMENT LAP SPLICES TO BE 18 INCHES
2. CDOT CLASS A OR B CONCRETE

BERKELEY WATER AND SANITATION DISTRICT

**CONCRETE
SEWER ENCASMENT**

NONE

Date: APRIL 2019

Revised:

Detail: 6

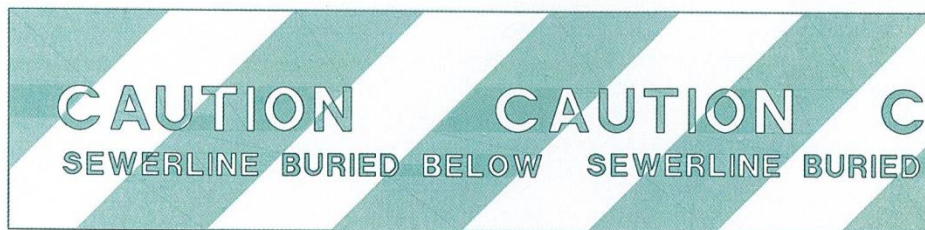

SOLID GREEN OR
GREEN AND WHITE STRIPES

TAPE TO BE PLACED CONTINUOUSLY, APPROXIMATELY 6
INCHES ABOVE THE TOP OF ALL SEWER PIPES, BOTH
MAIN LINE AND SERVICE LINE.

BERKELEY WATER AND SANITATION DISTRICT

**METALLIC
DETECTION TAPE**

Date: *APRIL 2019*

Revised:

Detail: 7

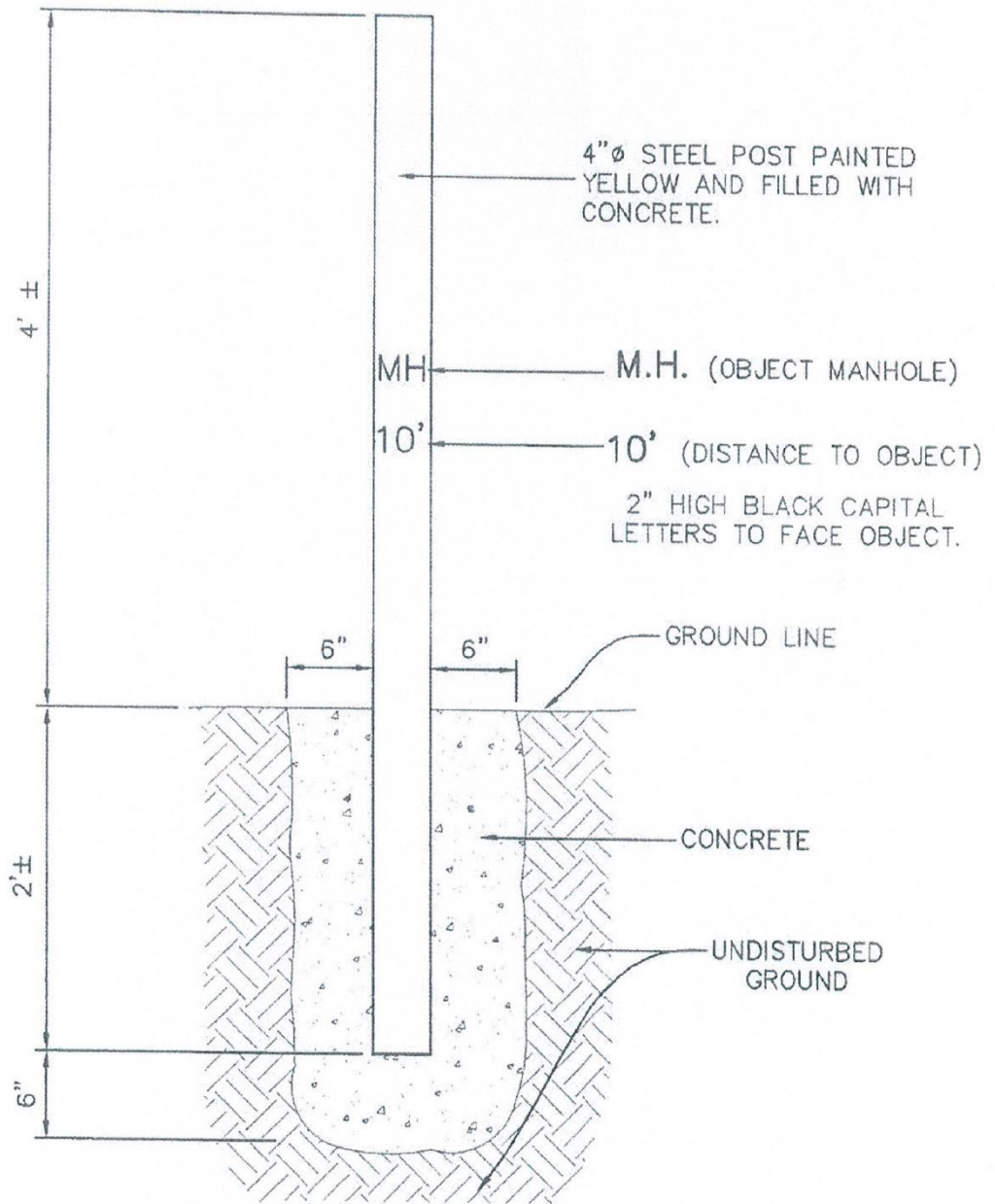

BERKELEY WATER AND SANITATION DISTRICT

**STEEL
MARKER POST**

Date: *APRIL 2019*

Revised:

Detail: *8*

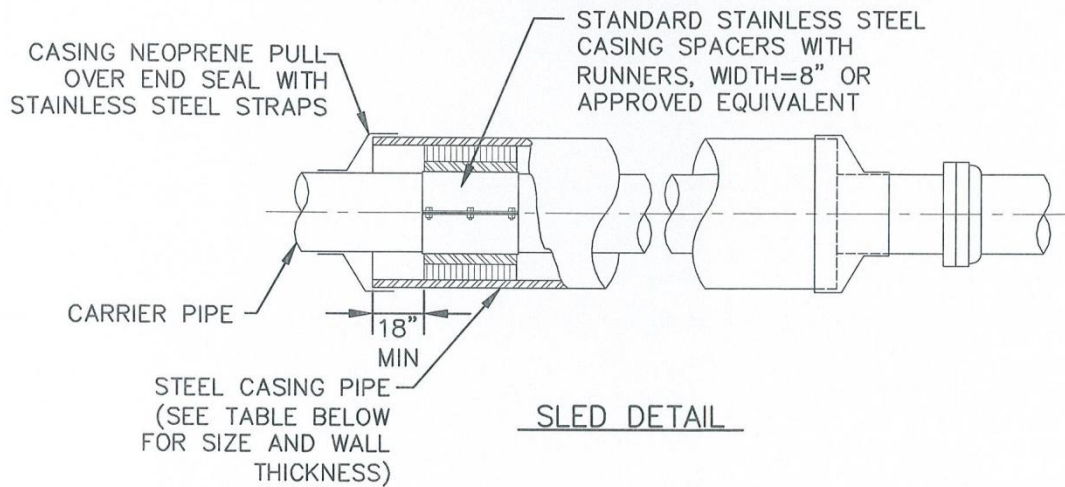

SLED DETAIL

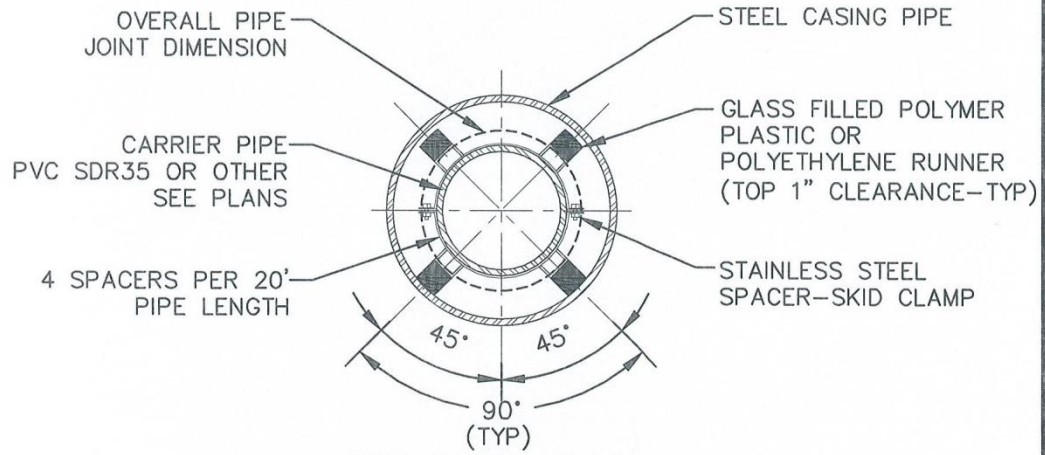

PIPE CASING DETAIL

CARRIER PIPE NOMINAL ϕ	CASING PIPE	
	MIN OD	MIN WALL THICKNESS
6"	16"	0.375"
8"	20"	0.375"
10"	24"	0.375"
12"	30"	0.375"
15"	36"	0.500"
18"	42"	0.500"
24"	48"	0.500"
30"	54"	0.500"

BERKELEY WATER AND SANITATION DISTRICT	
SANITARY SEWER BORE CASING	
Scale: <i>NONE</i>	Date: <i>APRIL 2019</i>
Revised:	Detail: <i>9</i>

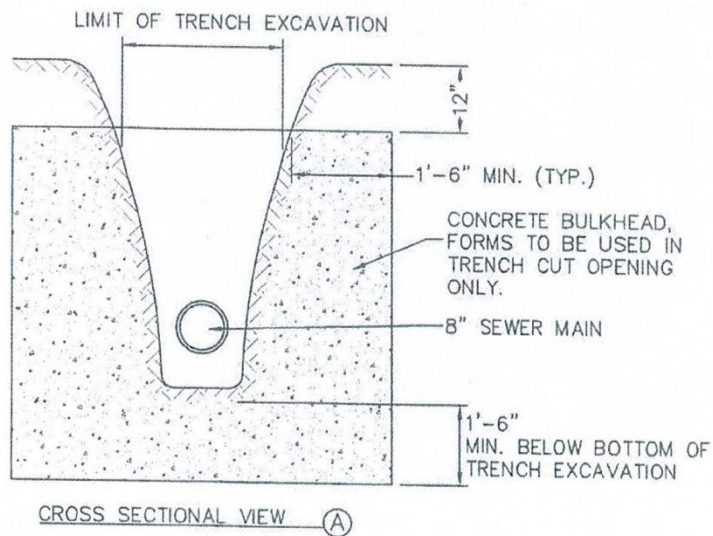
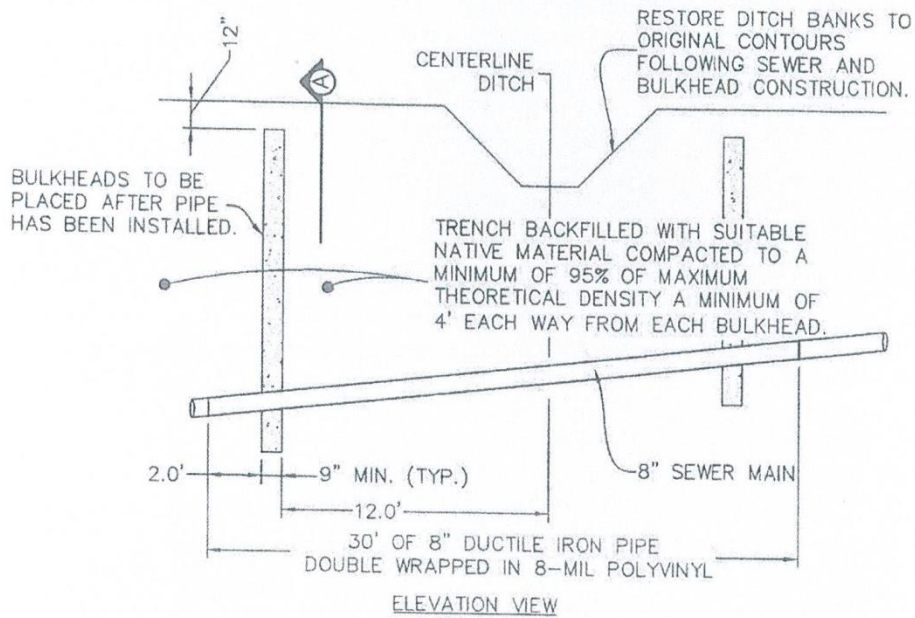

BERKELEY WATER AND SANITATION DISTRICT

**BULKHEAD
CONSTRUCTION**

Date: *APRIL 2019*

Revised:

Detail: *10*

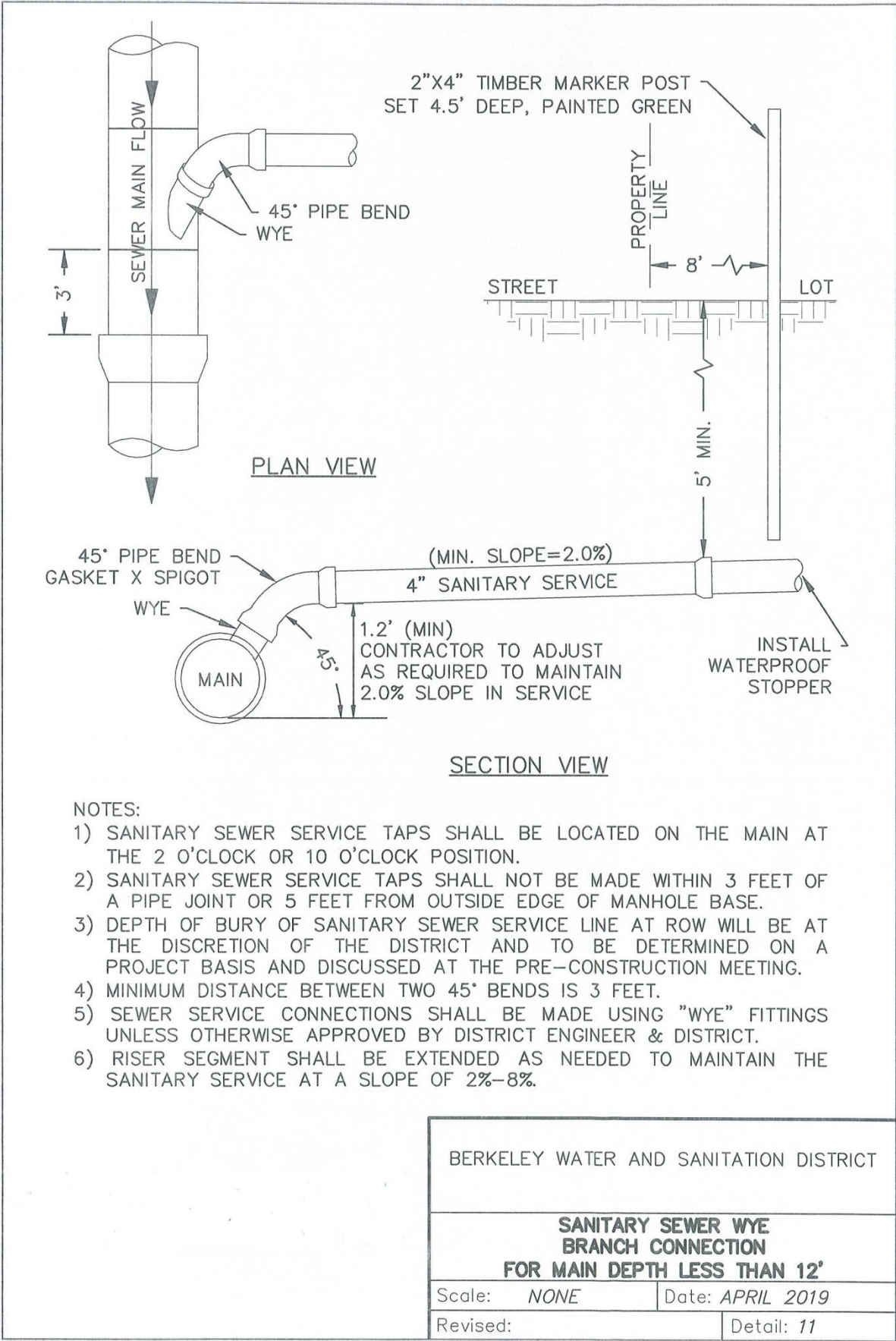

- NOTES:
- 1) SANITARY SEWER SERVICE TAPS SHALL BE LOCATED ON THE MAIN AT THE 2 O'CLOCK OR 10 O'CLOCK POSITION.
 - 2) SANITARY SEWER SERVICE TAPS SHALL NOT BE MADE WITHIN 3 FEET OF A PIPE JOINT OR 5 FEET FROM OUTSIDE EDGE OF MANHOLE BASE.
 - 3) DEPTH OF BURY OF SANITARY SEWER SERVICE LINE AT ROW WILL BE AT THE DISCRETION OF THE DISTRICT AND TO BE DETERMINED ON A PROJECT BASIS AND DISCUSSED AT THE PRE-CONSTRUCTION MEETING.
 - 4) MINIMUM DISTANCE BETWEEN TWO 45° BENDS IS 3 FEET.
 - 5) SEWER SERVICE CONNECTIONS SHALL BE MADE USING "WYE" FITTINGS UNLESS OTHERWISE APPROVED BY DISTRICT ENGINEER & DISTRICT.
 - 6) RISER SEGMENT SHALL BE EXTENDED AS NEEDED TO MAINTAIN THE SANITARY SERVICE AT A SLOPE OF 2%-8%.

BERKELEY WATER AND SANITATION DISTRICT	
SANITARY SEWER WYE BRANCH CONNECTION FOR MAIN DEPTH LESS THAN 12'	
Scale: <i>NONE</i>	Date: <i>APRIL 2019</i>
Revised:	Detail: <i>11</i>

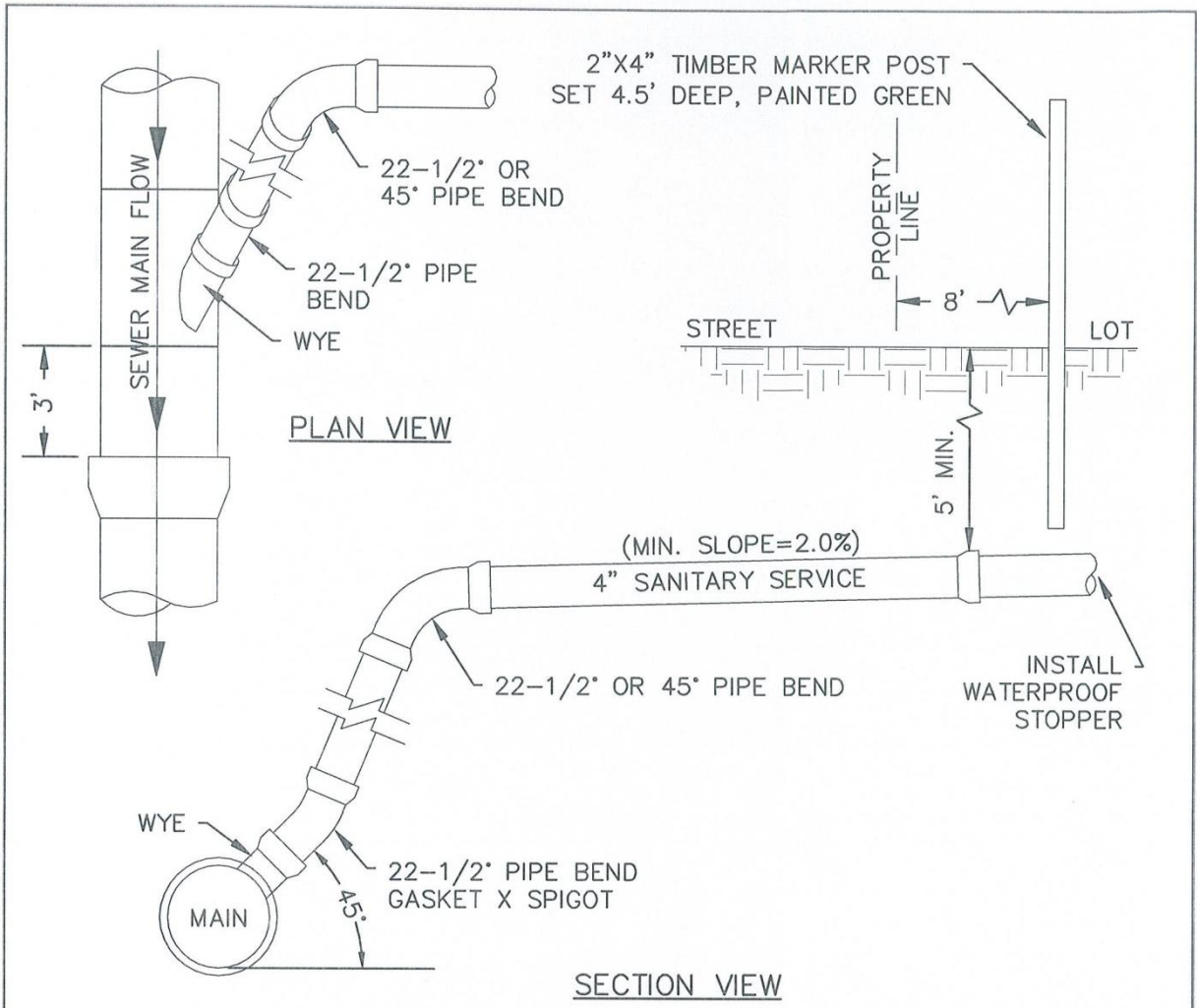

- NOTES:
- 1) SANITARY SEWER SERVICE TAPS SHALL BE LOCATED ON THE MAIN AT THE 2 O'CLOCK OR 10 O'CLOCK POSITION.
 - 2) SANITARY SEWER SERVICE TAPS SHALL NOT BE MADE WITHIN 3 FEET OF A PIPE JOINT OR 5 FEET FROM OUTSIDE EDGE OF MANHOLE BASE.
 - 3) DEPTH OF BURY OF SANITARY SEWER SERVICE LINE AT ROW WILL BE AT THE DISCRETION OF THE DISTRICT AND TO BE DETERMINED ON A PROJECT BASIS AND DISCUSSED AT THE PRE-CONSTRUCTION MEETING.
 - 4) MINIMUM DISTANCE BETWEEN TWO 45° BENDS IS 3 FEET.
 - 5) SEWER SERVICE CONNECTIONS SHALL BE MADE USING "WYE" FITTINGS UNLESS OTHERWISE APPROVED BY DISTRICT ENGINEER & DISTRICT.
 - 6) RISER SEGMENT SHALL BE EXTENDED AS NEEDED TO MAINTAIN THE SANITARY SERVICE AT A SLOPE OF 2%-8%.

BERKELEY WATER AND SANITATION DISTRICT	
SANITARY SEWER WYE BRANCH CONNECTION FOR MAIN DEPTH GREATER THAN 12'	
Scale: <i>NONE</i>	Date: <i>APRIL 2019</i>
Revised:	Detail: <i>12</i>

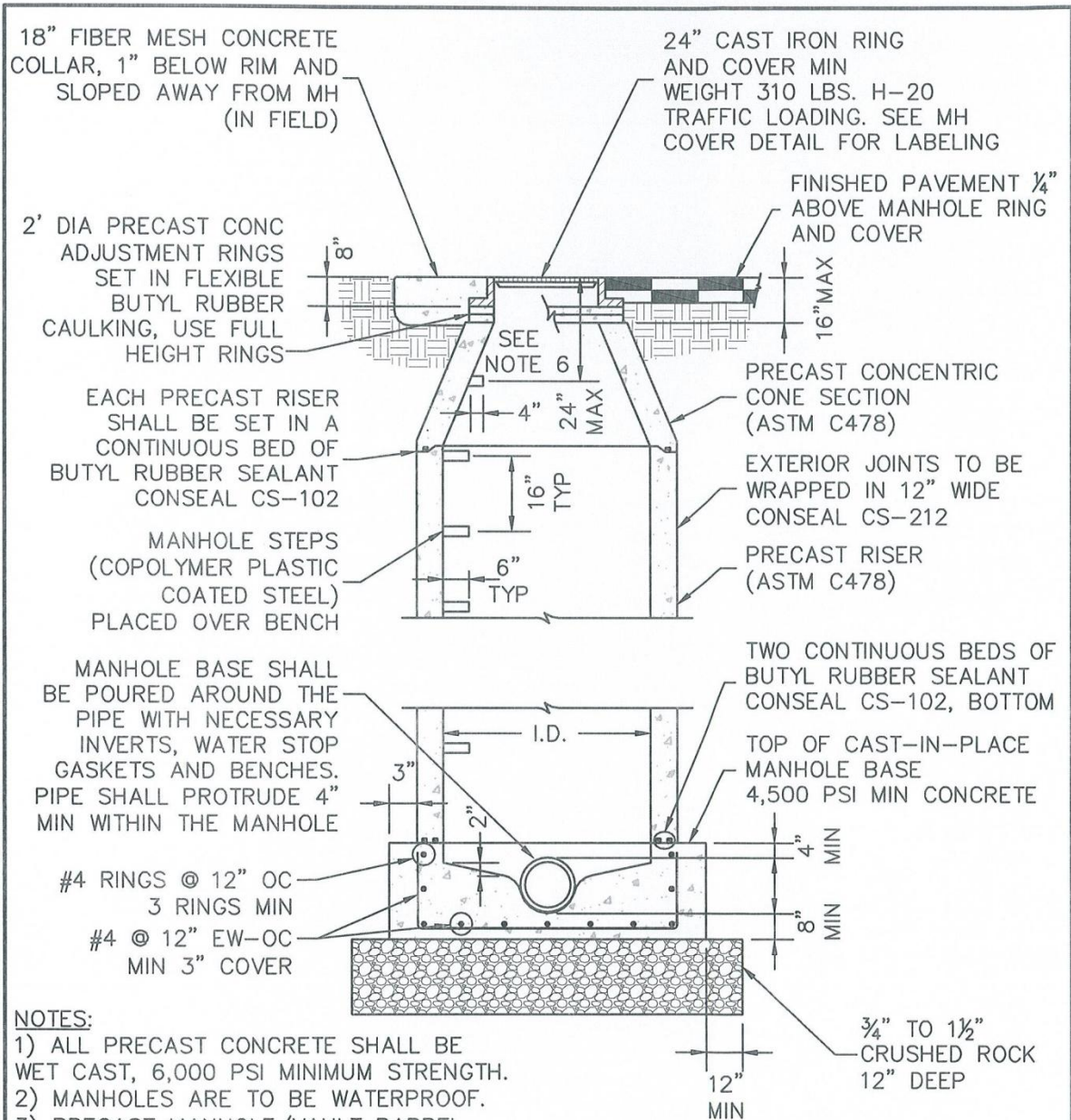

- NOTES:**
- 1) ALL PRECAST CONCRETE SHALL BE WET CAST, 6,000 PSI MINIMUM STRENGTH.
 - 2) MANHOLES ARE TO BE WATERPROOF.
 - 3) PRECAST MANHOLE/VAULT BARREL SECTIONS, WALLS AND BOTTOM OF BASE WILL REQUIRE AN EXTERIOR COATING OF BITUMINOUS WATERPROOFING OR APPROVED EQUIVALENT.
 - 4) THE BENCH SHALL HAVE A BRUSHED, NON-SKID SURFACE.
 - 5) 5' STUB-OUT PIPES SHALL CONTAIN WATER TIGHT PLUGS.
 - 6) A TWO-SIDED CONFINED SPACED WARNING TAG SHALL BE ATTACHED TO THE TOP STEP.

MANHOLE ID:
 ID=4' FOR SEWER MAIN DIAMETERS < 15"
 ID=5' FOR SEWER MAIN DIAMETERS 15"-36"
 ID=6' FOR SEWER MAIN DIAMETERS 42"-48"

BERKELEY WATER AND SANITATION DISTRICT	
SANITARY SEWER MANHOLE (CIP BASE)	
Scale: NONE	Date: APRIL 2019
Revised:	Detail: 13

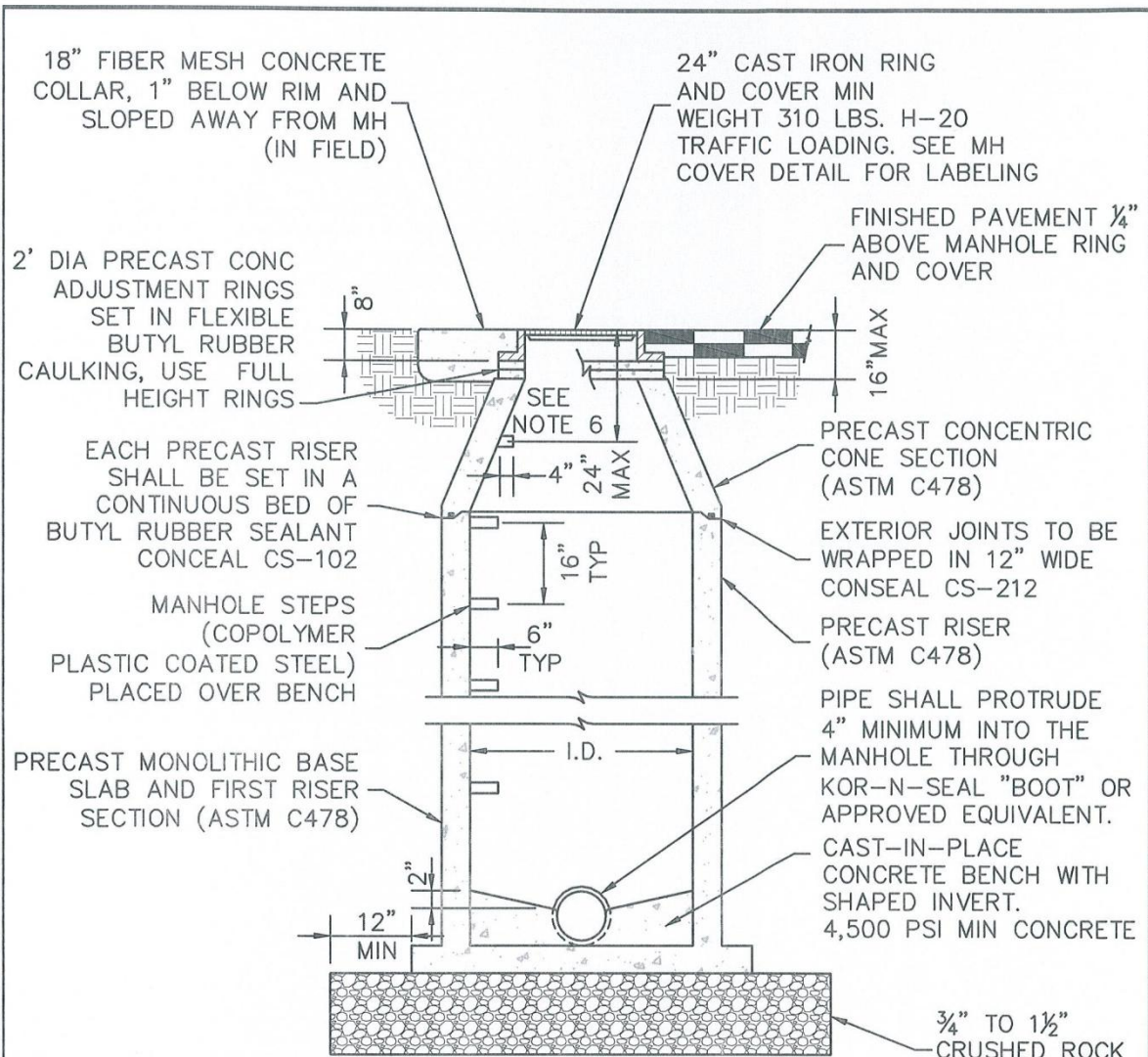

NOTES:

- 1) ALL PRECAST CONCRETE SHALL BE WET CAST 6,000 PSI MINIMUM STRENGTH.
- 2) MANHOLES ARE TO BE WATERPROOF.
- 3) PRECAST MANHOLE/VAULT BARREL SECTIONS, WALLS AND BOTTOM OF BASE WILL REQUIRE AN EXTERIOR COATING OF BITUMINOUS WATERPROOFING OR APPROVED EQUIVALENT.
- 4) THE BENCH SHALL HAVE A BRUSHED NON-SKID SURFACE.
- 5) 5' STUB-OUT PIPES SHALL CONTAIN WATER-TIGHT PLUGS.
- 6) A TWO-SIDED CONFINED SPACED WARNING TAG SHALL BE ATTACHED TO THE TOP STEP.

MANHOLE ID:

- ID=4' FOR SEWER MAIN DIAMETERS < 15"
- ID=5' FOR SEWER MAIN DIAMETERS 15"-36"
- ID=6' FOR SEWER MAIN DIAMETERS 42"-48"

BERKELEY WATER AND SANITATION DISTRICT	
SANITARY SEWER MANHOLE (PRECAST BASE)	
Scale: <i>NONE</i>	Date: <i>APRIL 2019</i>
Revised:	Detail: <i>14</i>



1. THE CONFINED SPACE WARNING TAG SHALL BE 15 MIL DOUBLE SIDED PVC PLASTIC OR POLYESTER WITH A 3/8" BRASS GROMMET WITH A 8" NYLON TIE. SIZE=3"X6" +/- OR APPROVED EQUIVALENT.
2. THE WARNING TAG SHALL BE FASTENED TO THE TOP STEP OF THE MH.

BERKELEY WATER AND SANITATION DISTRICT	
CONFINED SPACE SAFETY TAG	
Scale: <i>NONE</i>	Date: <i>APRIL 2019</i>
Revised:	Detail: <i>15</i>

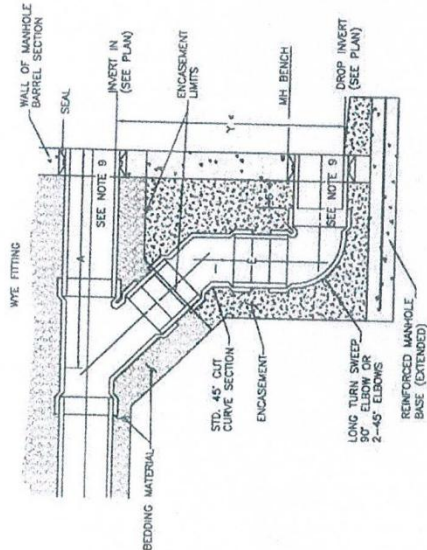

OUTSIDE DROP - DEEP - FOR PVC
NO SCALE

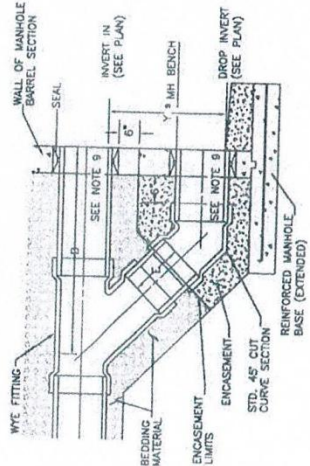

- GENERAL NOTES:
1. ALL PIPE AND FITTINGS TO BE ASTM AND CITY APPROVED.
 2. FOR PAYMENT PURPOSES, ALL FITTINGS, PIPE, CONCRETE ENCASEMENT SHALL BE INCLUDED IN THE UNIT PRICE OF THE OUTSIDE DROP.
 3. DIAMETER OF THE PIPE SHALL NOT BE LESS THAN MAIN LINE PIPE DIAMETER.
 4. FOR 18" DIAMETER AND LARGER, OUTSIDE DROP SHALL BE A SPECIAL DESIGN.
 5. THE APPROPRIATE INVERT, ADAPTOR OR CONNECTOR SHALL BE USED AND THE SPECIFIED PIPE MATERIAL, AND SHALL BE DRAW APPROVED.
 6. OUTSIDE DROP SHALL BE ALL OF ONE MATERIAL.
 7. CONCRETE ENCASEMENT SHALL BE A MINIMUM OF 6" THICK ALL AROUND.
 8. PIPE DIMENSIONS ARE APPROXIMATE AND MAY VARY FROM ONE MANUFACTURER TO ANOTHER.
 9. ALL REQUIRED WALL OPENINGS SHALL BE PRECAST BLOCK-OUT OR CAST-IN-PLACE. JACK-HAMMERING OF OPENINGS IS NOT ALLOWED.

DIMENSIONS (NOMINAL)		A (INCHES)		B (INCHES)		Y ₄ (INCHES)		Y ₈ (INCHES)									
PIPE DIAMETER (INCHES)		B	10	12	15	8	10	12	15	8	10	12	15				
POLYVYL CHLORIDE (PVC)		42	47	49	65	41	43	51	61	31	37	39	55	18	18	22	28

A MANHOLE OUTSIDE DROP IS NOT FEASIBLE FOR A DROP OF LESS THAN 18". THE ABOVE DIMENSIONS INDICATE ONLY THE MINIMUM DROP OBTAINABLE WITH AVAILABLE MATERIAL. GREATER DIMENSIONS INDICATE POSSIBLE BY ADDITION OF THE APPROPRIATE PIPE LENGTH AT DIMENSION E.

BERKELEY WATER AND SANITATION DISTRICT

**STANDARD
DROP MANHOLE**

Date: APRIL 2019

Revised: _____ Detail: 16

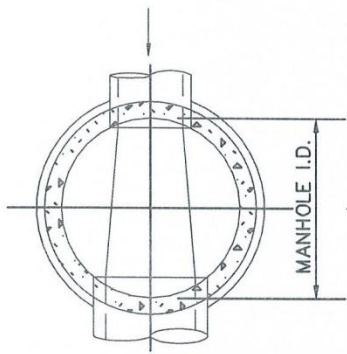

THROUGH PIPE

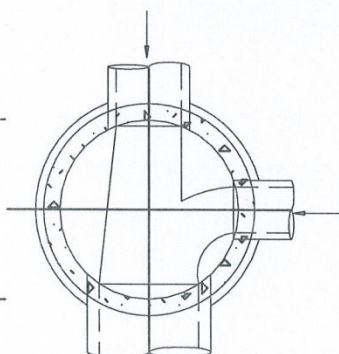

THROUGH PIPE
ONE COLLECTION LINE

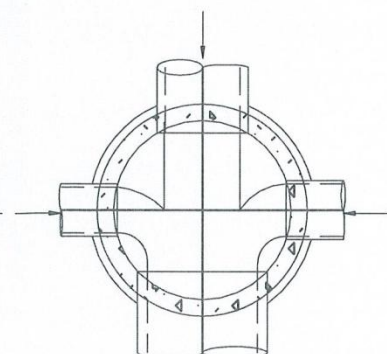

THROUGH PIPE
TWO COLLECTION LINES

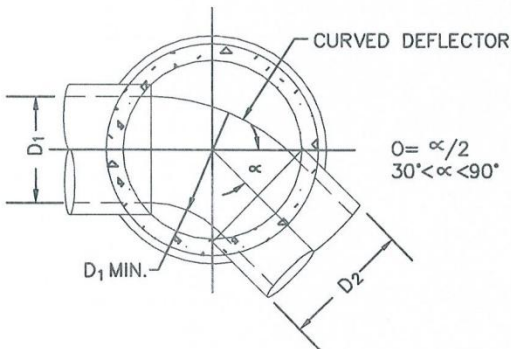

INTERMEDIATE ANGLE

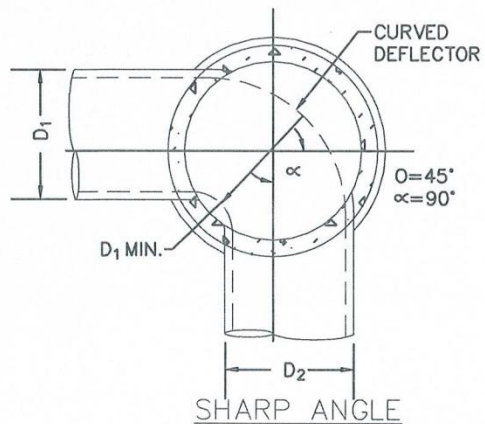

SHARP ANGLE

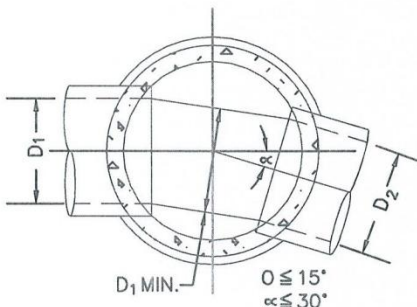

INTERMEDIATE ANGLE

NOTE:
1. DETAILS SHOWN ARE TYPICAL
ONLY FOR INSTALLATIONS
WITH A MAXIMUM OF UP TO
(INSIDE DROP)
18 INCH DIFFERENCE IN INVERTS.

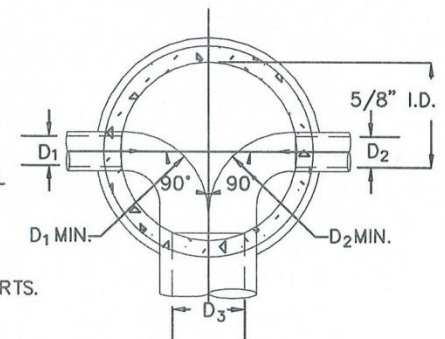

OPPOSED LATERALS

BERKELEY WATER AND SANITATION DISTRICT	
MANHOLE BASE & DEFLECTOR	
NONE	Date: APRIL 2019
Revised:	Detail: 17

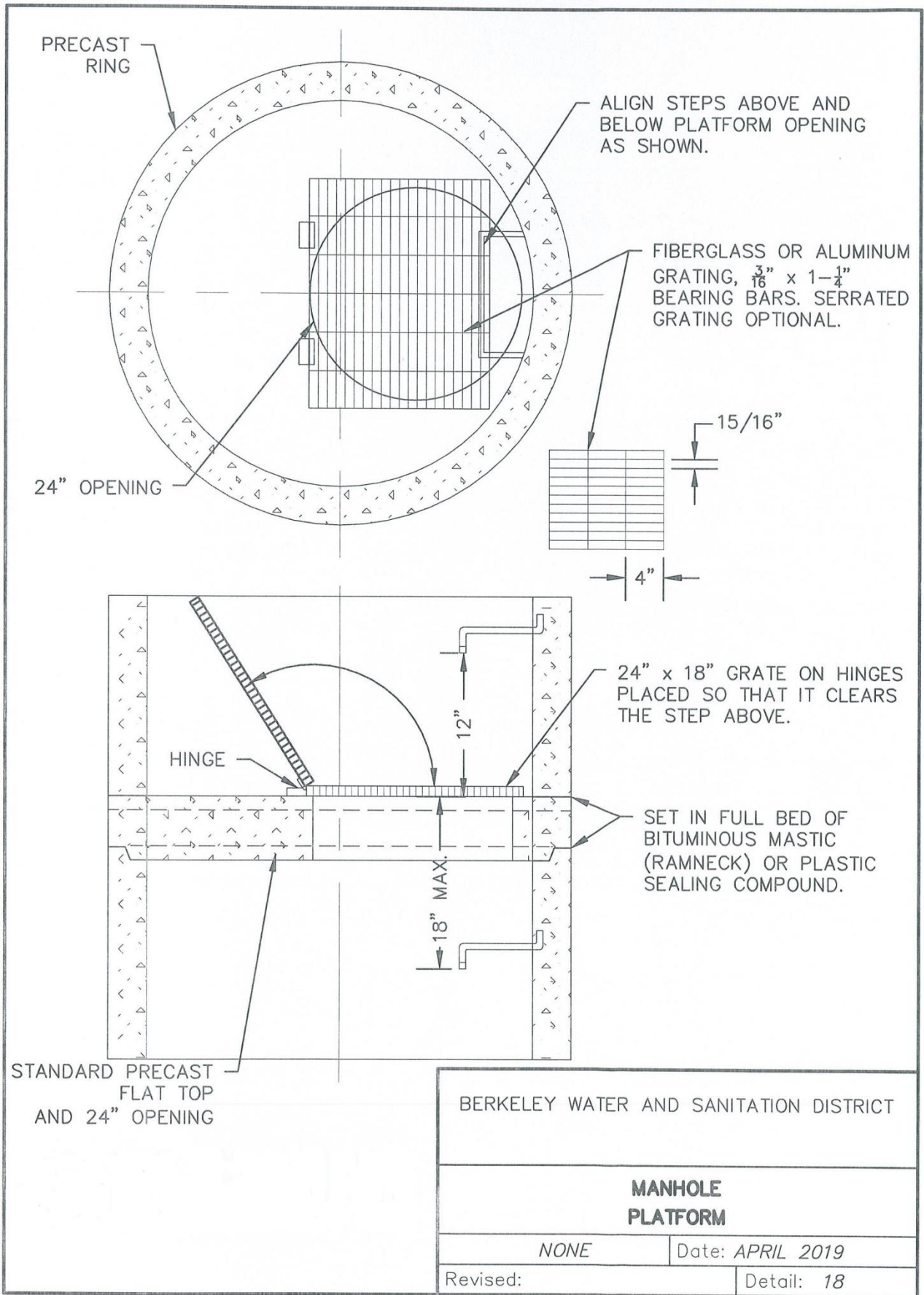

PRECAST RING

ALIGN STEPS ABOVE AND BELOW PLATFORM OPENING AS SHOWN.

FIBERGLASS OR ALUMINUM GRATING, $\frac{3}{16}$ " x $1\frac{1}{4}$ " BEARING BARS. SERRATED GRATING OPTIONAL.

24" OPENING

$\frac{15}{16}$ "

4"

HINGE

24" x 18" GRATE ON HINGES PLACED SO THAT IT CLEARS THE STEP ABOVE.

12"

SET IN FULL BED OF BITUMINOUS MASTIC (RAMNECK) OR PLASTIC SEALING COMPOUND.

18" MAX.

STANDARD PRECAST FLAT TOP AND 24" OPENING

BERKELEY WATER AND SANITATION DISTRICT

MANHOLE PLATFORM

NONE

Date: APRIL 2019

Revised:

Detail: 18

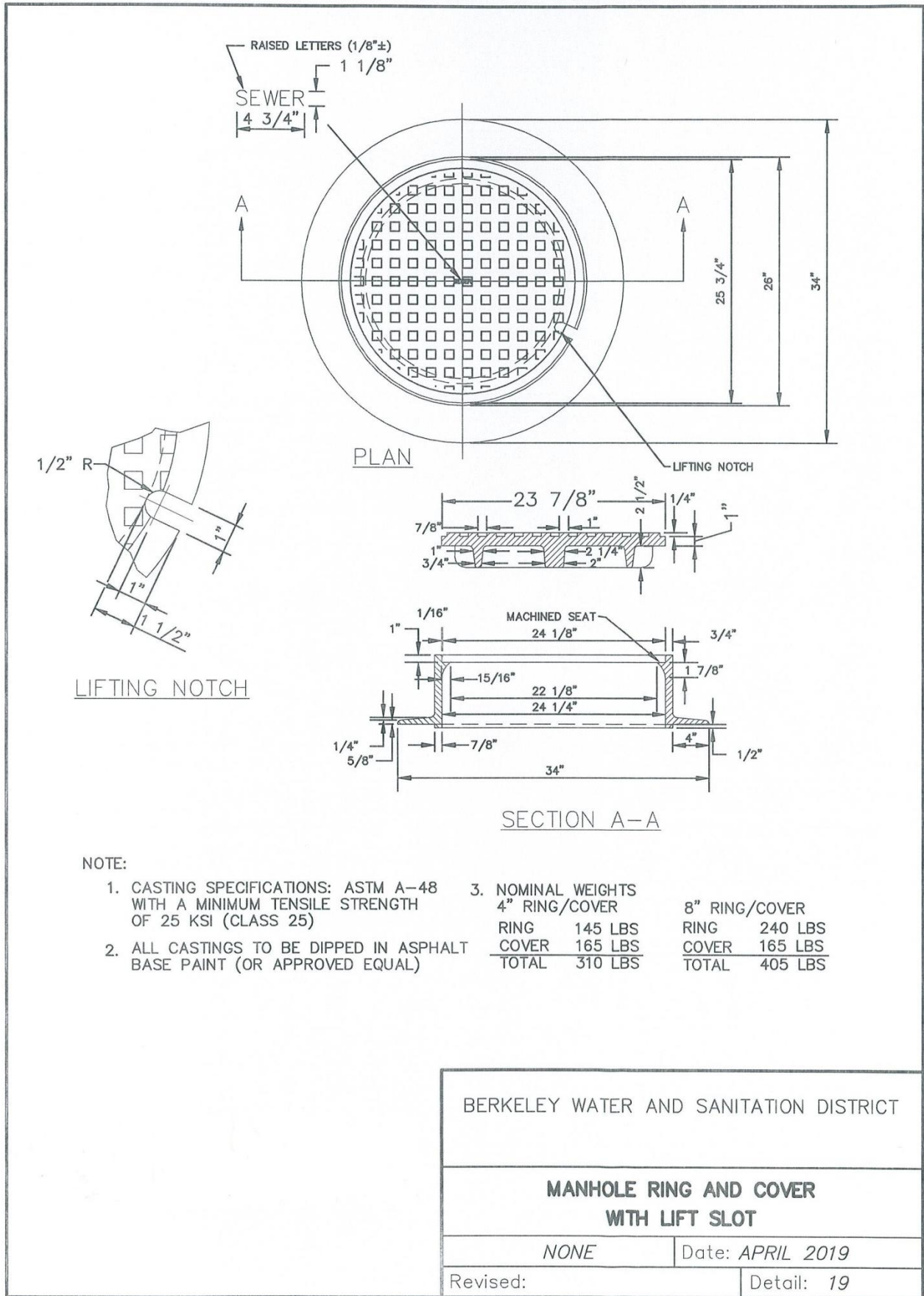

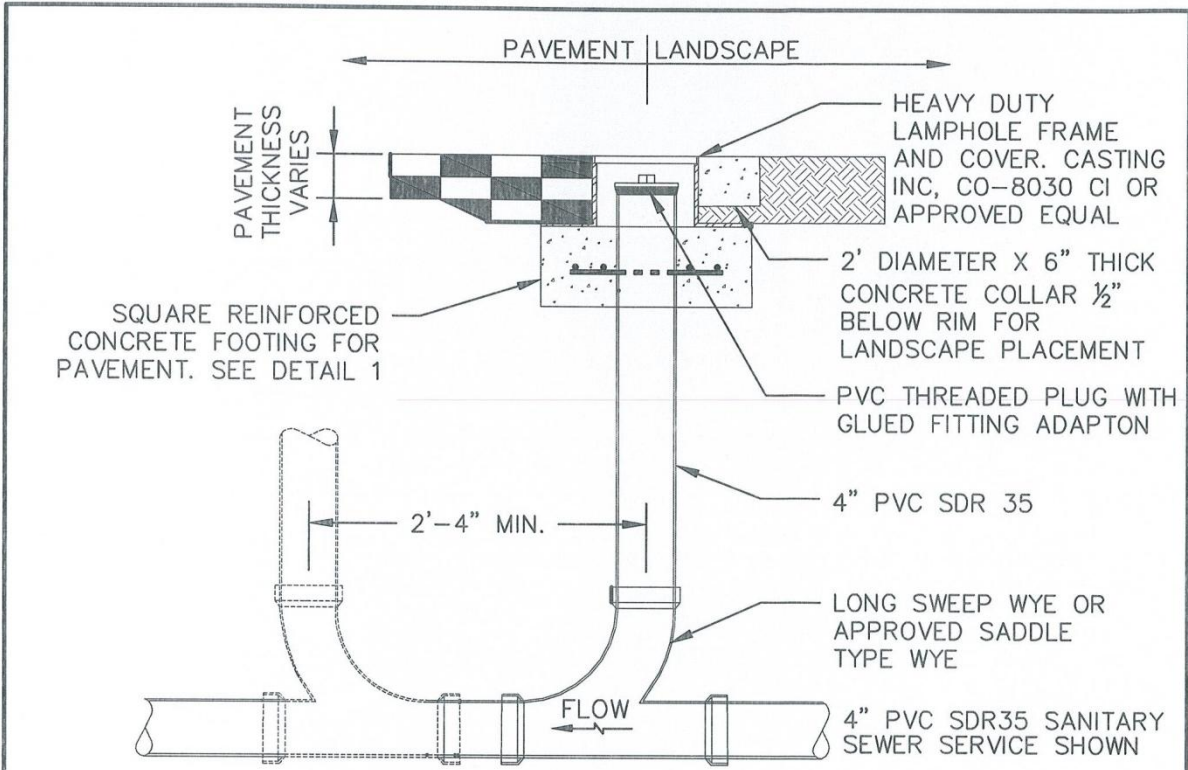

**CLEANOUT ELEVATION
FOR 4" & 6" SANITARY
SEWER SERVICE LINES**

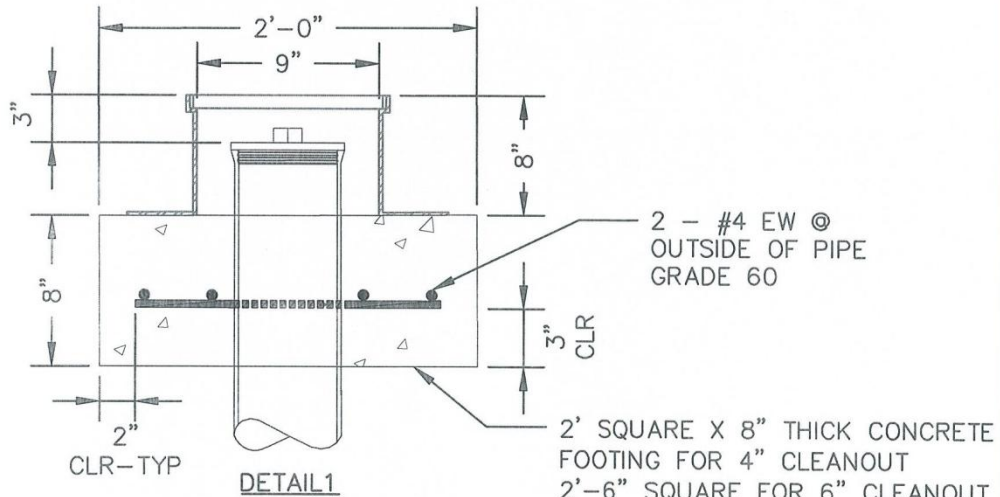

- NOTES:**
1. CLEANOUT PIPE DIAMETER TO MATCH SEWER SERVICE PIPE.
 2. COVER AND RIM TO BE 1/4" LOWER THAN PAVEMENT.
 3. OPTIONAL TWO WAY CLEANOUT AS SPECIFIED ON PLANS.

BERKELEY WATER AND SANITATION DISTRICT	
TWO-WAY CLEAN-OUT	
Scale: <i>NONE</i>	Date: <i>APRIL 2019</i>
Revised:	Detail: <i>20</i>

TABLE IV			
MIN. DEPTH OF BEDDING MAT'L. BELOW BOTTOM OF PIPE			
PIPE SIZE-D*	d ₁	d ₂	d ₃
18" & SMALLER	4"	6"	6"
21" TO 36"	6"	6"	6"
42" TO 60"	6"	6"	6"
66" TO 96"	8"	9"	9"
104" & LARGER	12"	12"	12"

B_d=SPECIFIED TRENCH WIDTH AT A POINT 12" ABOVE CROWN (MAX. ALLOWANCE)

B_c=PIPE O.D.

D =PIPE I.D.

d₁,d₂,d₃=DEPTH OF BEDDING MATERIAL BELOW BOTTOM OF PIPE.

NOTES:

3.1 BELL HOLES SHALL BE EXCAVATED AT ALL BELL AND SPIGOT JOINTS.

3.2 BEDDING TRENCH BACKFILL TO BE COMPACTED TO 90% DENSITY, AASHTO T-180 IN OPEN AREAS AND 95% DENSITY AASHTO T-99 IN ALL PUBLIC R.O.W.

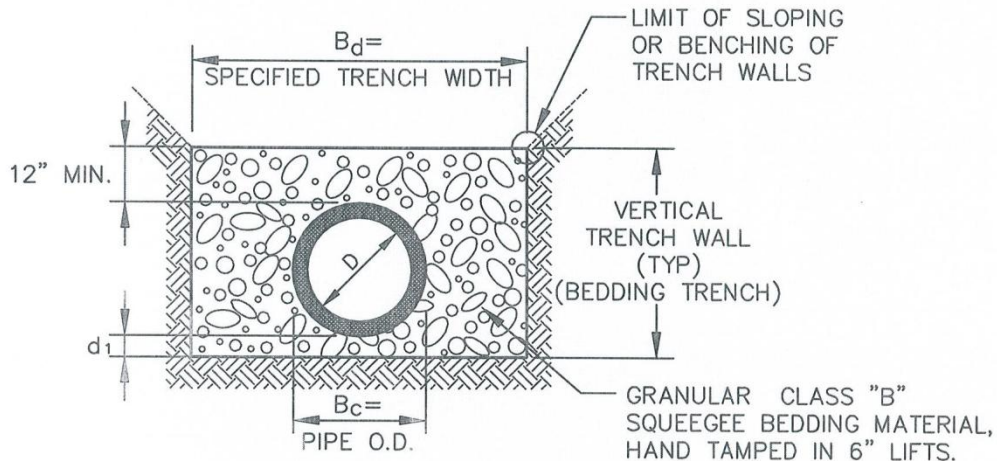

IDEAL TRENCH CONDITIONS
 15" DIA. & SMALLER
 N.T.S.

CLASS "B" BEDDING MATERIAL SHALL CONSIST OF A WELL GRADED MIXTURE OF MINERAL AGGREGATE. THE AGGREGATE SHALL BE SQUEEGEE WITH A MAXIMUM AMOUNT OF FINES PASSING A NO. 200 SCREEN NOT TO EXCEED 5% BY WEIGHT. THE AGGREGATE SHALL COMPLY WITH ASTM C-33 OR ASTM D-448, GRADATION #6 OR #67. IF THE EXCAVATION FOR BEDDING IS BELOW THE WATER TABLE, THE SUB-BEDDING MATERIAL SHALL CONSIST OF 3/4-INCH TO 1-1/2-INCH CRUSHED ROCK.

BERKELEY WATER AND SANITATION DISTRICT	
SANITARY SEWER PIPE BEDDING	
Scale: NONE	Date: APRIL 2019
Revised:	Detail: 21

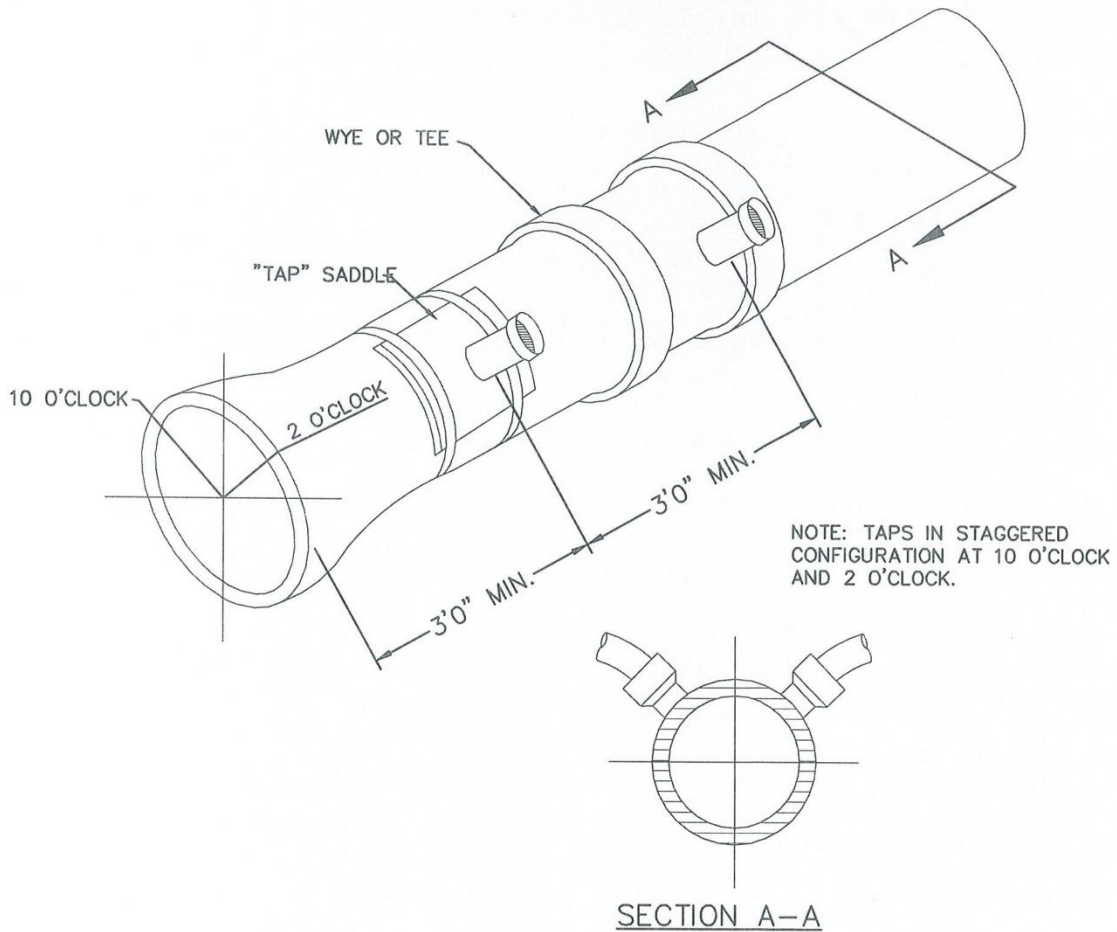

SEWER

1. SEWER SERVICE CONNECTIONS SHALL BE POSITIONED AT EITHER THE 2 O'CLOCK OR THE 10 O'CLOCK POSITION ON THE CIRCUMFERENCE OF THE SEWER MAIN.
2. ON NEW INSTALLATIONS, EITHER WYE OR TEE FITTINGS SHALL BE USED. WHEN TAPPING INTO AN EXISTING SEWER MAIN, A SADDLE CONNECTION AND APPROVED CORING METHOD SHALL BE USED.
3. THE MINIMUM DISTANCE BETWEEN SERVICE CONNECTIONS MADE ALONG THE PIPE SHALL BE 3-FEET. THE MINIMUM DISTANCE FROM EITHER THE BELL OR SPIGOT END OF A PIPE SHALL BE 3-FEET. THE MINIMUM DISTANCE FROM THE CENTER OF A MANHOLE TO A SERVICE CONNECTION SHALL BE EITHER 5-FEET OR THE TRANSITION POINT FROM THE MANHOLE TRENCH, WHICHEVER IS GREATER.
4. A MAXIMUM OF 4 SEWER SERVICE CONNECTIONS SHALL BE ALLOWED PER 20-FEET LENGTH OF PIPE. A SPECIFIC SOILS INVESTIGATIONS SHOULD BE CONDUCTED TO ASSURE THAT THE EXTERNAL LOADING WILL BE WITHIN ALLOWABLE LIMITS REGARDLESS OF THE NUMBER OF TAPS INVOLVED.
5. WITH AWWA C-900 CLASS 200 PIPE USE AWWA C-900 CLASS 150 TEES FOR SERVICES.

BERKELEY WATER AND SANITATION DISTRICT

**SEWER
TAPPING**

NONE

Date: APRIL 2019

Revised:

Detail: 22